

NOTE: FLAG ITEMS ▶

REFER TO INSTRUCTION DRAWINGS

ITEM NO.	PART NUMBER	DESCRIPTION	QTY.
1	MFG21004	LS1/LS2 12v Alternator Relocation LH	1
2	MFG21031	LS1/LS2 12v Alternator Relocation RH	1
3	MFC20020	Bracket - AUX Alternator Setup Coil Relocation	1
4	MFC1819-LS2VE	Power Steering Reservoir Bracket - LS2/3 VE - VF	1
5	UBH16 - 300 x 500N	90° 16 x 300 x 500 Universal Hose Bend - Fuel & Oil	1
6	MFC651	Spacer 10 x 20 x 51 L P/ST	2
7	6PK2450	Drive Belt - Poly Rib (2440mm)	1
8	16-25-9W2	Hose Clamp - 16 to 25mm	2
9	BT-2270	BOLT - M10 X 1.5 X 80mm - H/T - Z/P	2
10	BT-2130	M6 x 1.25 x 20 - Capture Bolt	2
11	FW-2010	Flat Washer - M10 x 22 x 2mm	3
12	SW-2005	Spring Washer - M10 - S/S	2
13	SHCS-2125	SHCS - M6 x 1 x 12mm - SS	1
14	MFC21007	VE Power Steering Pump Hose Barb	1

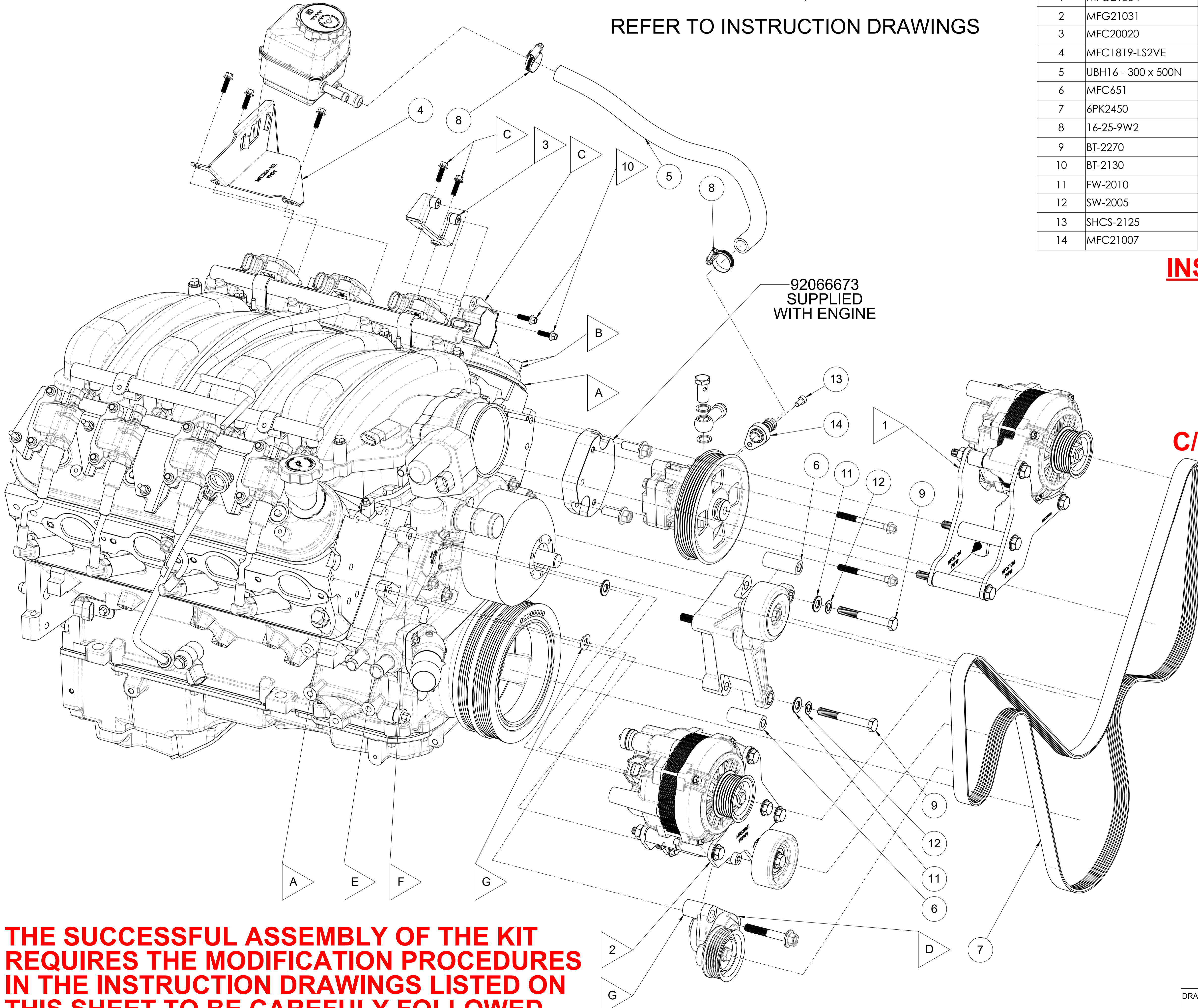

92066673
SUPPLIED
WITH ENGINE

INSTRUCTION DRAWINGS
MFK50190-VZ-SHT-1
MFK50190-VZ-SHT-2
1: MFG21004
2: MFG21031
A: LS - ACCMOD - 01
B: LS - ACCMOD - 02
C/3/10: LS - ACCMOD - 04
D: LS - ACCMOD - 10
E: LS - ACCMOD - 11
F: LS - INFO - 02
G: LS - INFO - 06

**THE SUCCESSFUL ASSEMBLY OF THE KIT
 REQUIRES THE MODIFICATION PROCEDURES
 IN THE INSTRUCTION DRAWINGS LISTED ON
 THIS SHEET TO BE CAREFULLY FOLLOWED**

DRAWN	GDK 15/07/2021	TITLE:	Accessory Kit - LH/RH 12v Alt
DRAWING CHECKED	PAM 12/08/2021	SCALE: 1:2.5	DRAWING/PART NUMBER
FINISHED WEIGHT: kg		DRAWING 1 of 2	MFK50190-VZ
			REV No. 0



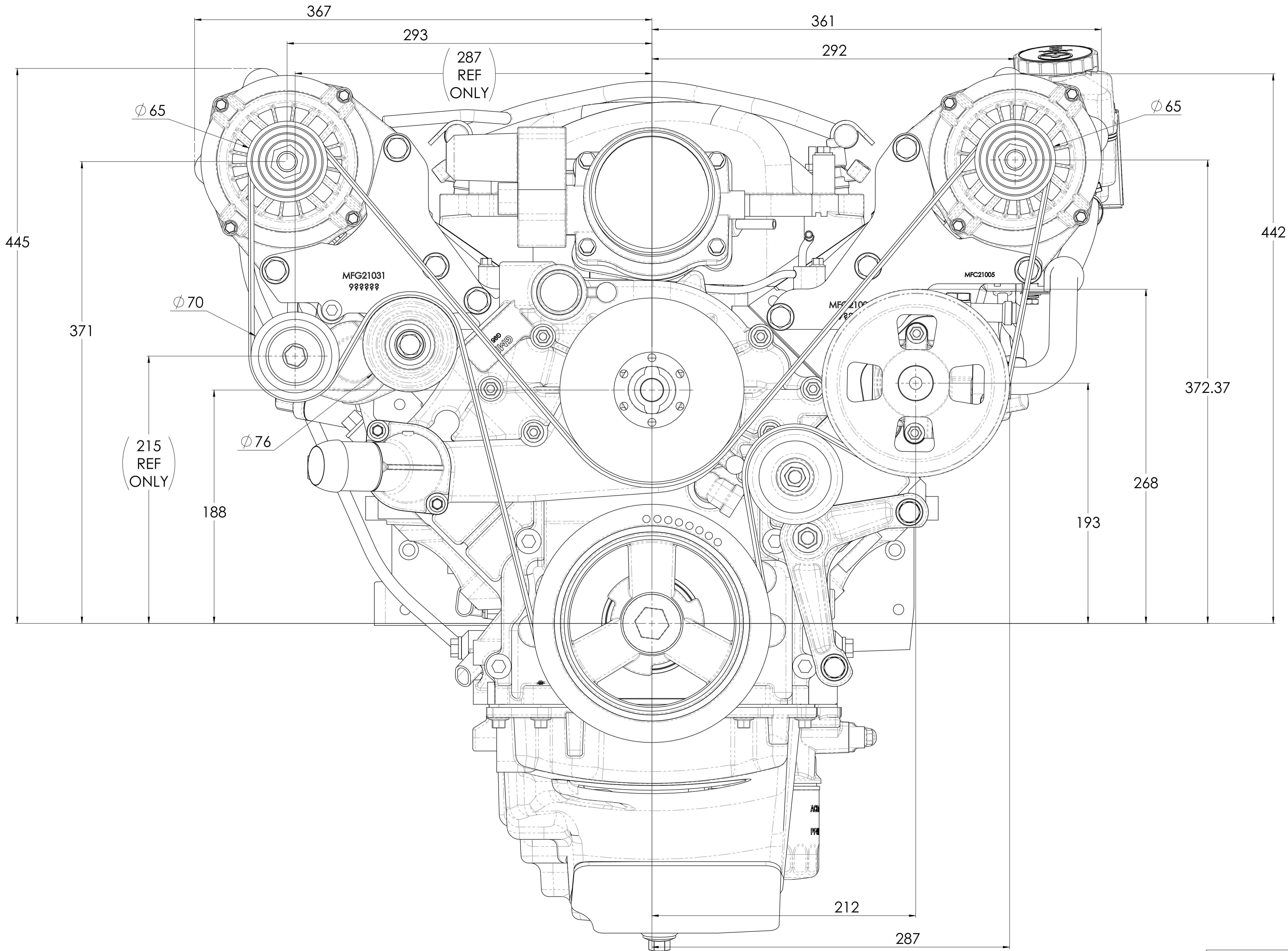

DRAWN	GDK 15/07/2021	TITLE:	()	
DRAWING CHECKED	PAM 12/08/2021	SCALE: 1:1.5	DRAWING/PART NUMBER	REV No.
FINISHED WEIGHT: kg		DRAWING 4 of 13	MFK50190-VZ	0

ITEM NO.	PART NUMBER	DESCRIPTION	QTY
1	MFC21004	LS1/LS2 12v Alternator Base Plate RH	1
2	MFC21005	LS1/LS2 12v Alternator Relocation Front Plate LH	1
3	BT-2180	BOLT - M10 X 1.5 X 100mm - H/T - Z/P	1
4	BT-2185	Bolt - M10 X 1.5 X 110mm - H/T (8.8) - Z/P	3
5	FW-2010	Flat Washer - M10 x 22 x 2mm	6
6	NT-2010	Nut - M10 X 1.5 - Z/P	3
7	PS-5	Hose Clamp	1
8	SHCS-2045	SHCS - M10 x 1.5 x 30mm - Z/P	1
9	BT-2010	Bolt - M6 x 1 x 12mm Capture Spring Washer	1
10	0369010	M10 x 1.5 Cone Lock Nut Metric	1

NOTE: ALL NT-2010
TO BE DISCARDED
AFTER INSTALL

NOTE: MEDIUM THREAD LOCK
ON ALL THREADS

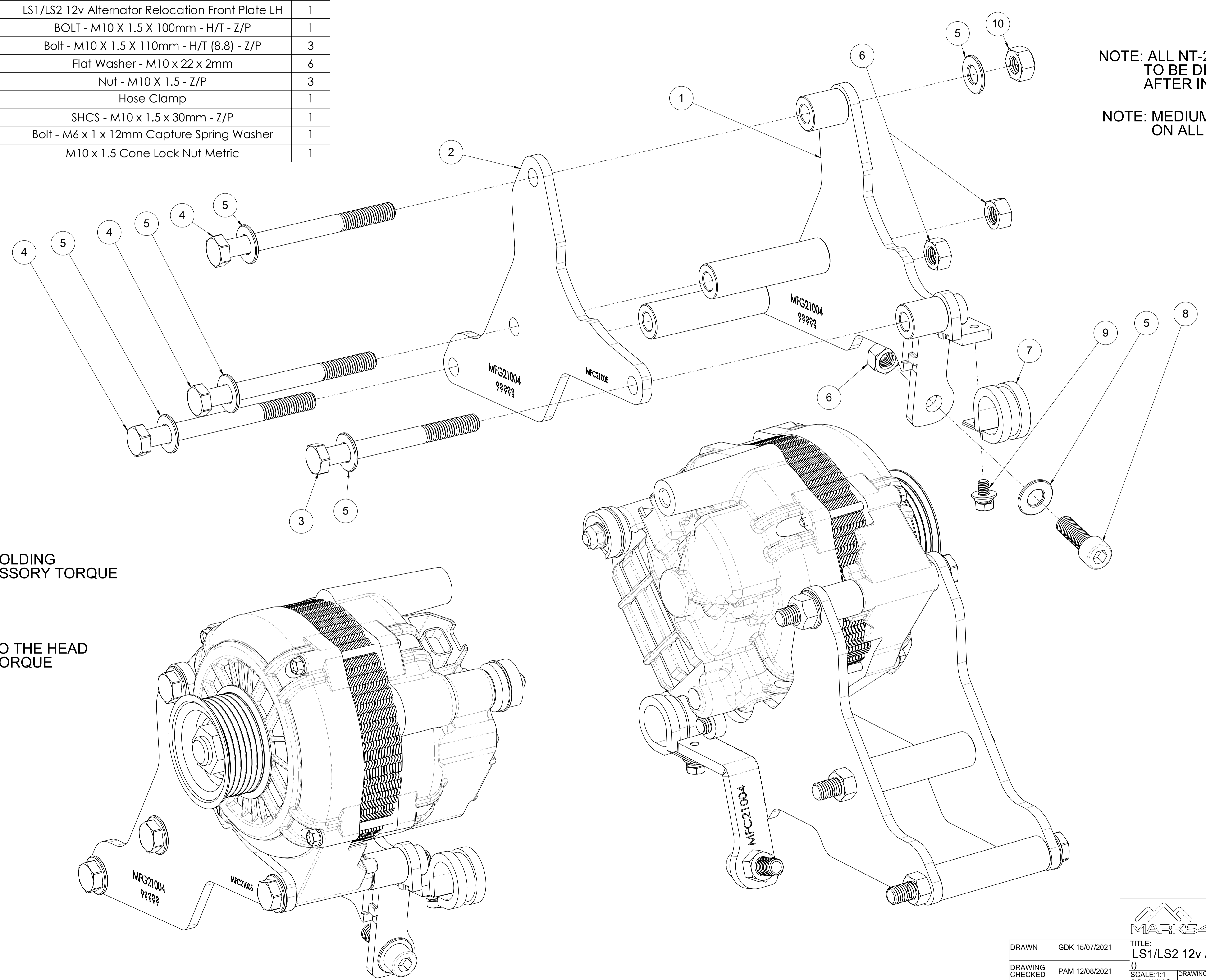

2 BOLTS HOLDING
12 V ACCESSORY TORQUE
TO 65Nm

BOLTS INTO THE HEAD
& BLOCK TORQUE
TO 45Nm



DRAWN	GDK 15/07/2021	TITLE:	LS1/LS2 12v Alternator Relocation LH	
DRAWING CHECKED	PAM 12/08/2021	SCALE: 1:1	DRAWING/PART NUMBER	REV No.
FINISHED WEIGHT: kg		DRAWING 1 of 1	MFC21004	0

ITEM NO.	PART NUMBER	DESCRIPTION	QTY
1	MFC21031	LS1/LS2 12v Alternator Relocation Base Plate RH	1
2	MFC21032	LS1/LS2 12v Alternator Relocation Front Plate RH	1
3	MFC21030	SHCS M10 x 1.5 x 130 - Low Head	1
4	BT-2282	BOLT - M10 X 1.5 X 130mm - H/T - Z/P	3
5	BT-2240	BOLT - M10 X 1.5 X 25mm - H/T - Z/P	2
6	BT-2175	BOLT - M10 X 1.5 X 75mm - H/T - Z/P	1
7	BT-2265	BOLT - M10 X 1.5 X 60mm - H/T - Z/P	1
8	FW-2010	Flat Washer - M10 x 22 x 2mm	11
9	NT-2010	Nut - M10 X 1.5 - Z/P	4
10	0369010	M10 x 1.5 Cone Lock Nut Metric	3
11	EPO24	Idler Pulley 76 O.D x 29.5 W x 17 I.D	1
12	FW-2005	Flat Washer - M10 x 21 x 1.1 - S/S	2

NOTE: SHIM THE TENSIONER IF REQUIRED

NOTE: ALL NT-2010 TO BE DISCARDED AFTER INSTALL

NOTE: MEDIUM THREAD LOCK ON ALL THREADS

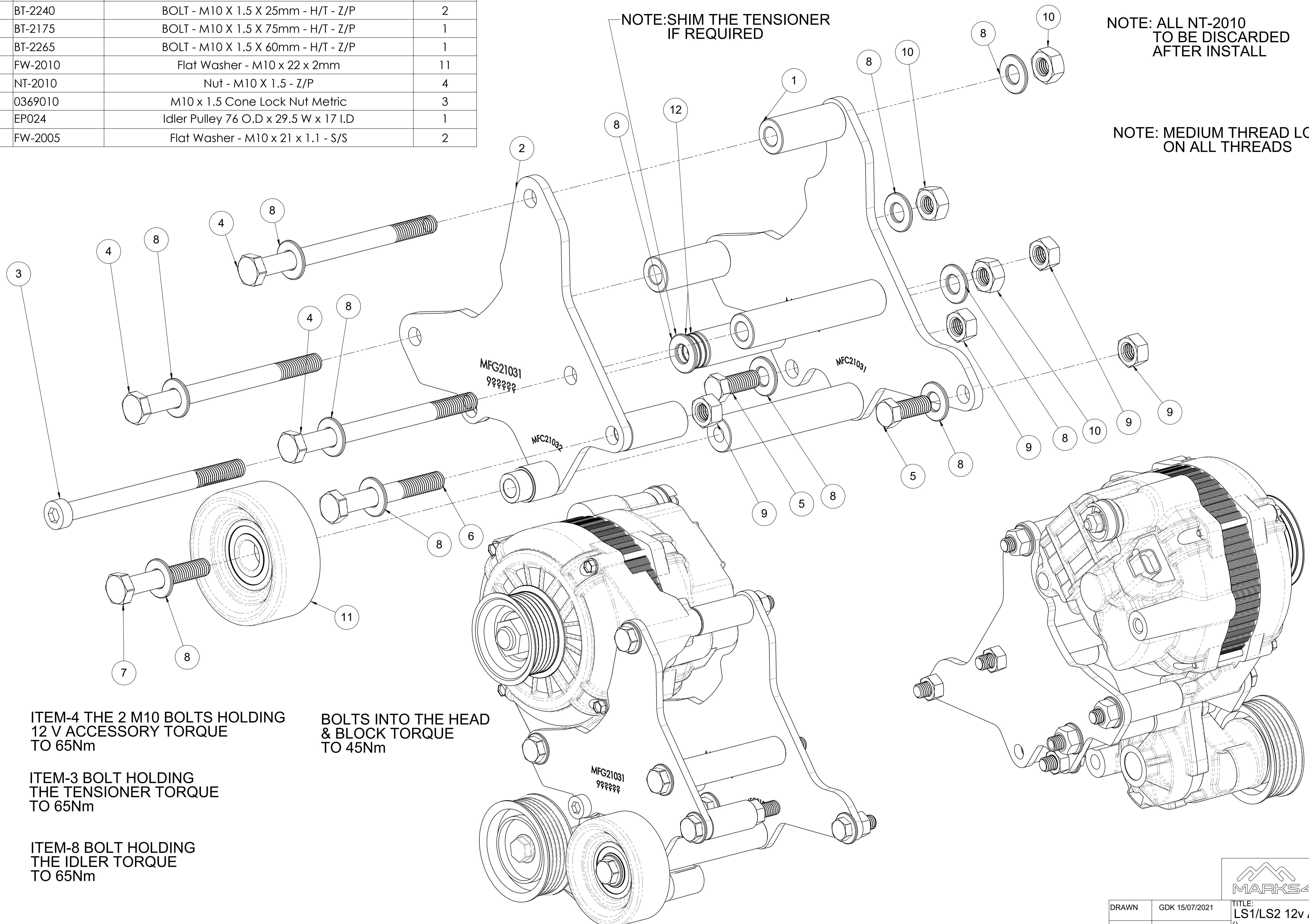

ITEM-4 THE 2 M10 BOLTS HOLDING 12 V ACCESSORY TORQUE TO 65Nm

BOLTS INTO THE HEAD & BLOCK TORQUE TO 45Nm

ITEM-3 BOLT HOLDING THE TENSIONER TORQUE TO 65Nm

ITEM-8 BOLT HOLDING THE IDLER TORQUE TO 65Nm



DRAWN	GDK 15/07/2021	TITLE:	LS1/LS2 12v Alternator Relocation RH
DRAWING CHECKED	PAM 12/08/2021	SCALE: 1:1	DRAWING/PART NUMBER
FINISHED WEIGHT: kg		DRAWING of 1	MFG21031
			REV No. 0

LS - SERIES ROCKER COVER LIP MODIFICATION

STANDARD ROCKER COVER

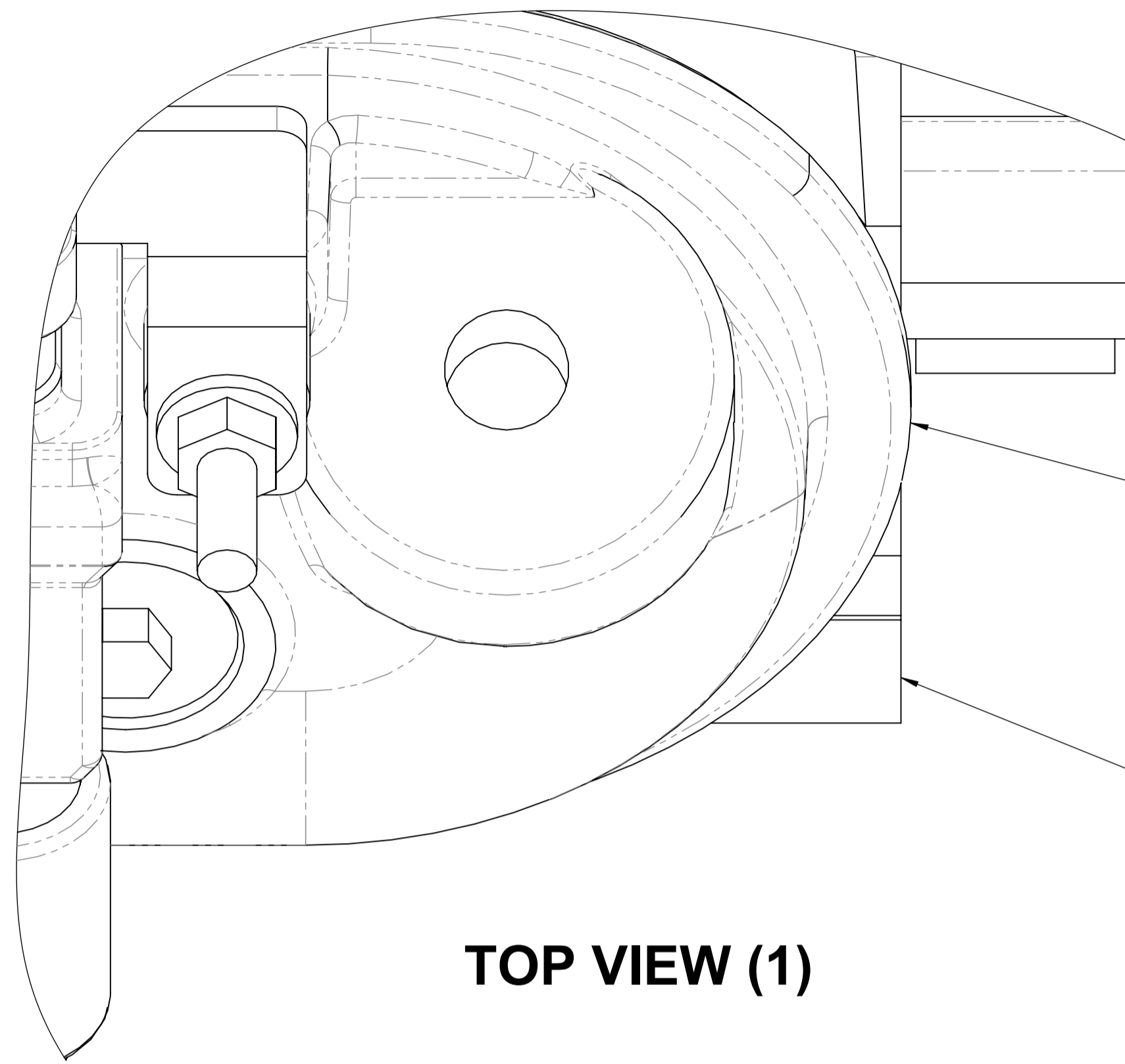

TOP VIEW (1)

THE LIP MODIFICATION SHOWS THE DRIVER SIDE CYLINDER HEAD FITTED WITH THE PASSENGER SIDE ROCKER COVER

PASSENGER SIDE ROCKER COVER LIP SITS ABOVE THE CYLINDER HEAD

DRIVER SIDE CYLINDER HEAD FACE SHOWN

MODIFIED ROCKER COVER

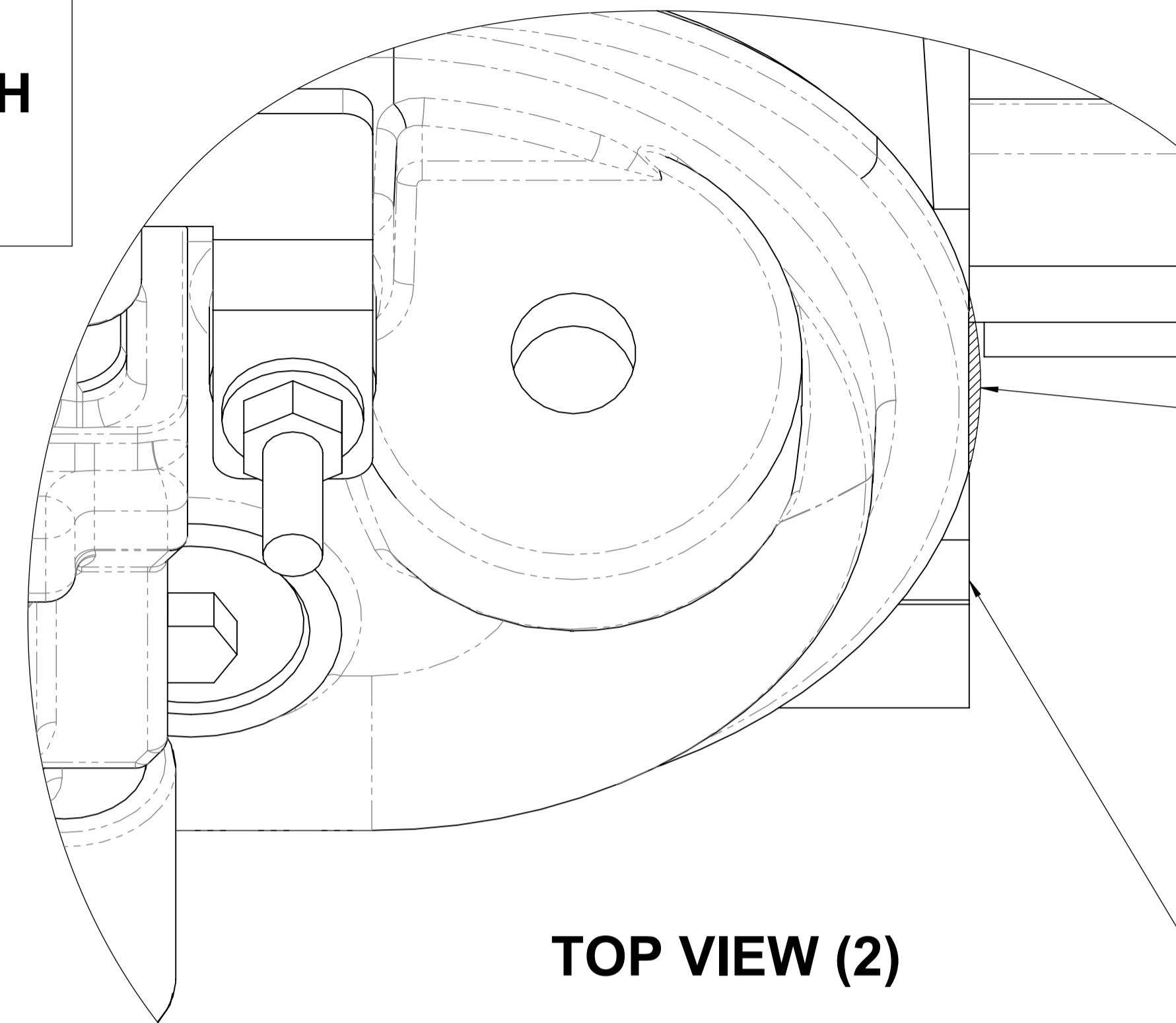

TOP VIEW (2)

DRIVER SIDE ROCKER COVER LIP REMOVE THE HATCHED AREA AS SHOWN

SHAVED ROCKER LIP SHOULD LOOK LIKE THE SIDE VIEW (2) BELOW

DRIVER SIDE CYLINDER HEAD FACE SHOWN

THE ROCKER COVER LIP MODIFICATION WILL ALSO BE REQUIRED FOR THE DRIVER SIDE ROCKER COVER WHEN IT IS FITTED TO THE PASSENGER SIDE CYLINDER HEAD IF A LH ACCESSORY KIT IS TO BE FITTED

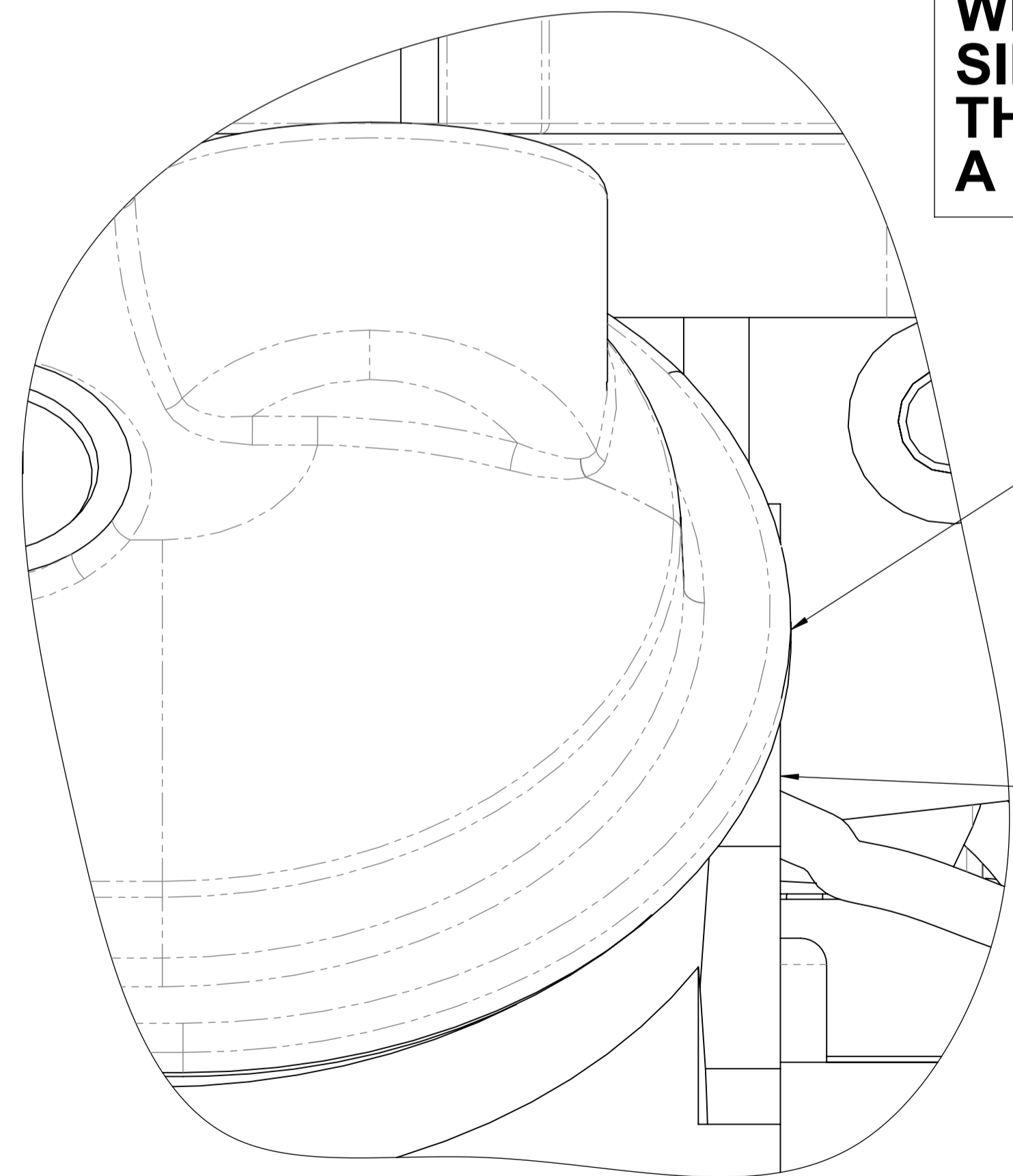

SIDE VIEW (1)

PASSENGER SIDE ROCKER COVER LIP SITS ABOVE THE CYLINDER HEAD

DRIVER SIDE CYLINDER HEAD FACE SHOWN

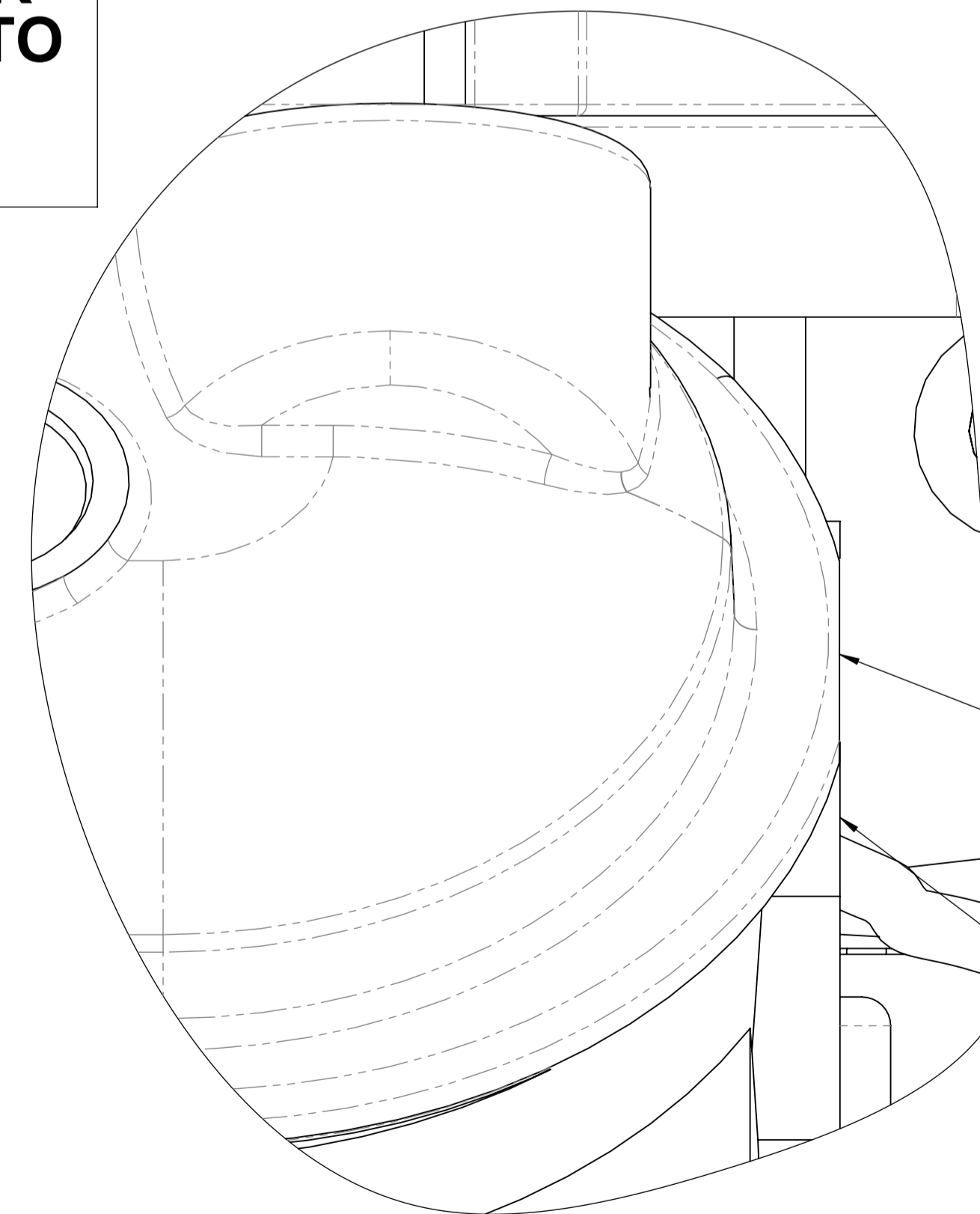

SIDE VIEW (2)

THE LIP OVER HANG MUST BE SHAVED BACK TO THE CYLINDER HEAD FACE

CAUTION: DO NOT SHAVE PAST THE CYLINDER HEAD & ENCROACH INTO THE O RING GROOVE

PASSENGER SIDE ROCKER COVER LIP SHAVED

DRIVER SIDE CYLINDER HEAD FACE SHOWN



DRAWN	GDK 15/07/2021	TITLE:	LS - Series Rocker Cover Lip Modification	
DRAWING CHECKED	PAM 12/08/2021	()	DRAWING/PART NUMBER	REV No.
FINISHED WEIGHT: kg		SCALE: 2:1	LS - ACCMOD - 01	0
		DRAWING 1 of 1		

LS - SERIES ROCKER COVER COIL BOSS MODIFICATION (ROCKER COVERS IN FACTORY POSITION)

STANDARD ROCKER COVER

THE BOSS MODIFICATION SHOWS THE PASSENGER SIDE ROCKER COVER ON THE PASSENGER SIDE CYLINDER HEAD

MODIFIED ROCKER COVER (OPTION-1)

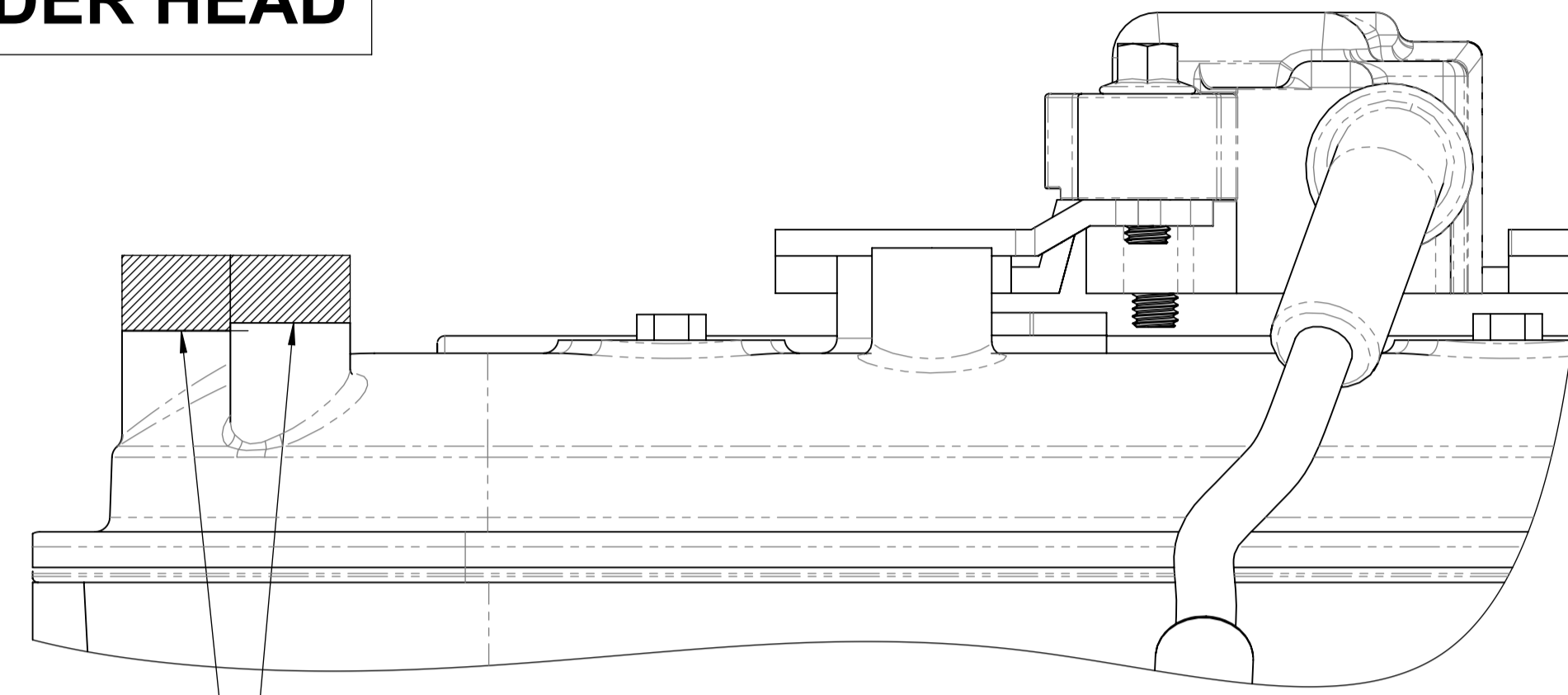
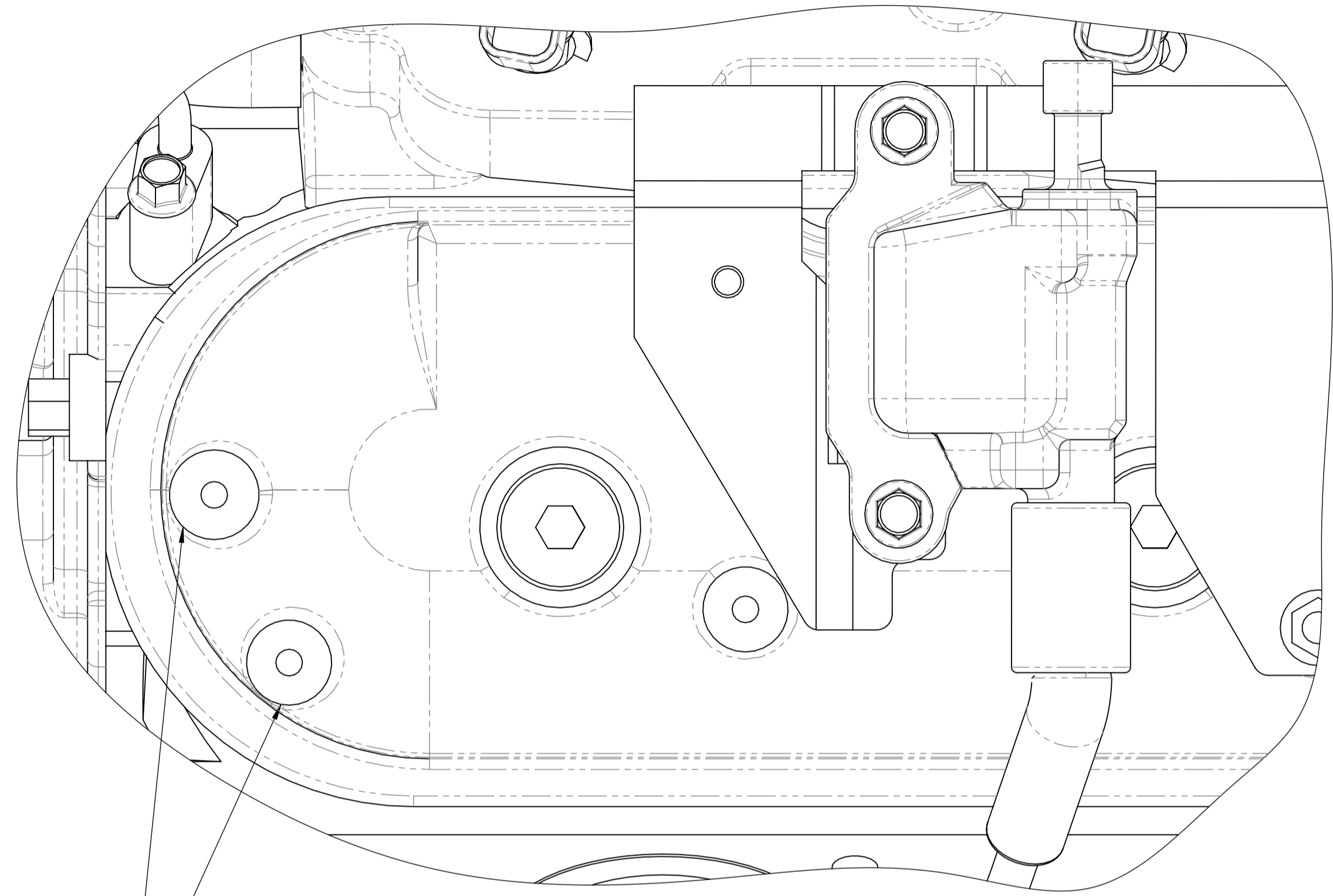

SIDE VIEW (2)

PASSENGER SIDE ROCKER COVER

REMOVE THE HATCHED AREA AS SHOWN ABOVE UNTIL THE CLEARANCE FOR THE ACCESSORY KIT IS ACHIEVED

THE STANDARD HEIGHT OF THE 2 MOUNTING BOSSES NEED TO BE MODIFIED
DECIDE FROM EITHER (OPTION-1) OR (OPTION-2)

MODIFIED ROCKER COVER (OPTION-2)

MOUNTING BOSSES TO BE MODIFIED

TOP VIEW (1)

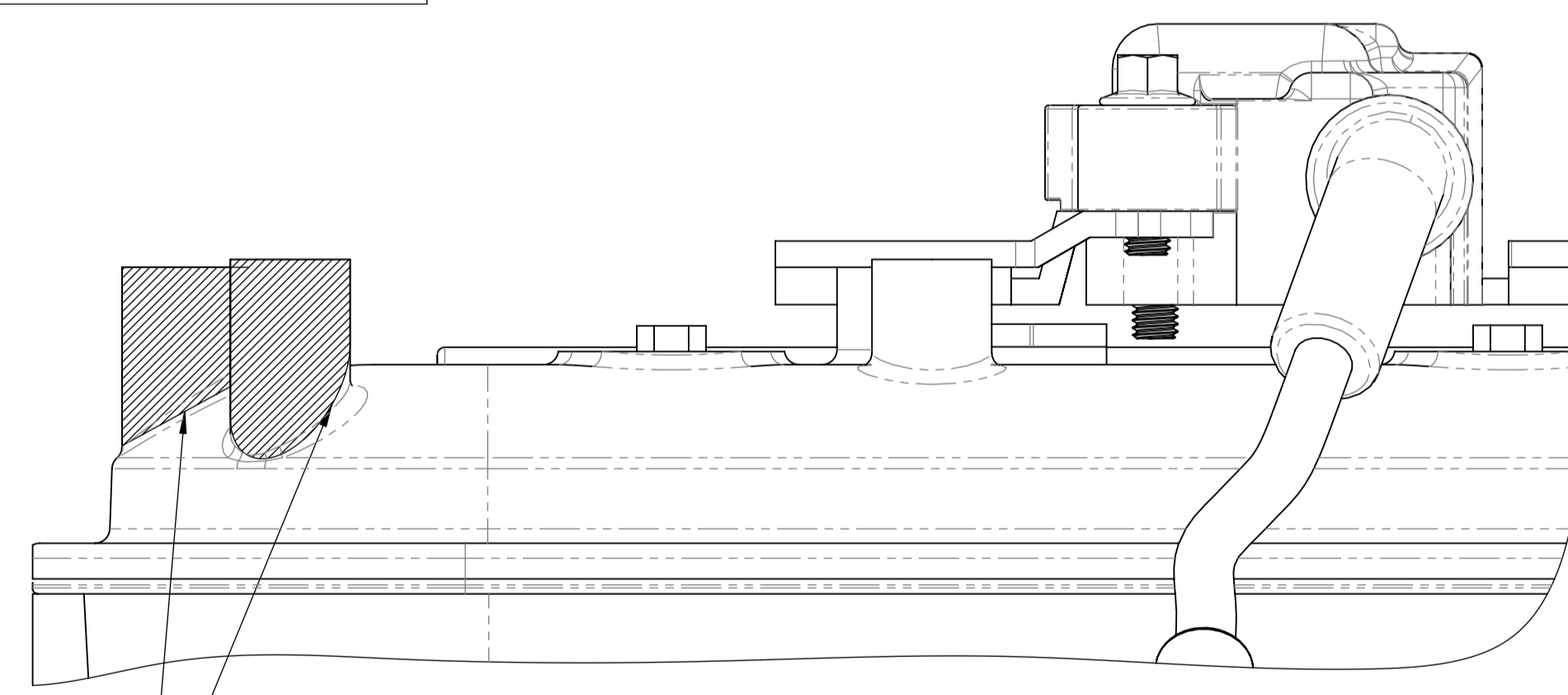

SIDE VIEW (3)

PASSENGER SIDE ROCKER COVER

REMOVE THE HATCHED AREA AS SHOWN ABOVE & SMOOTH OFF TO MATCH SHAPE OF COVER

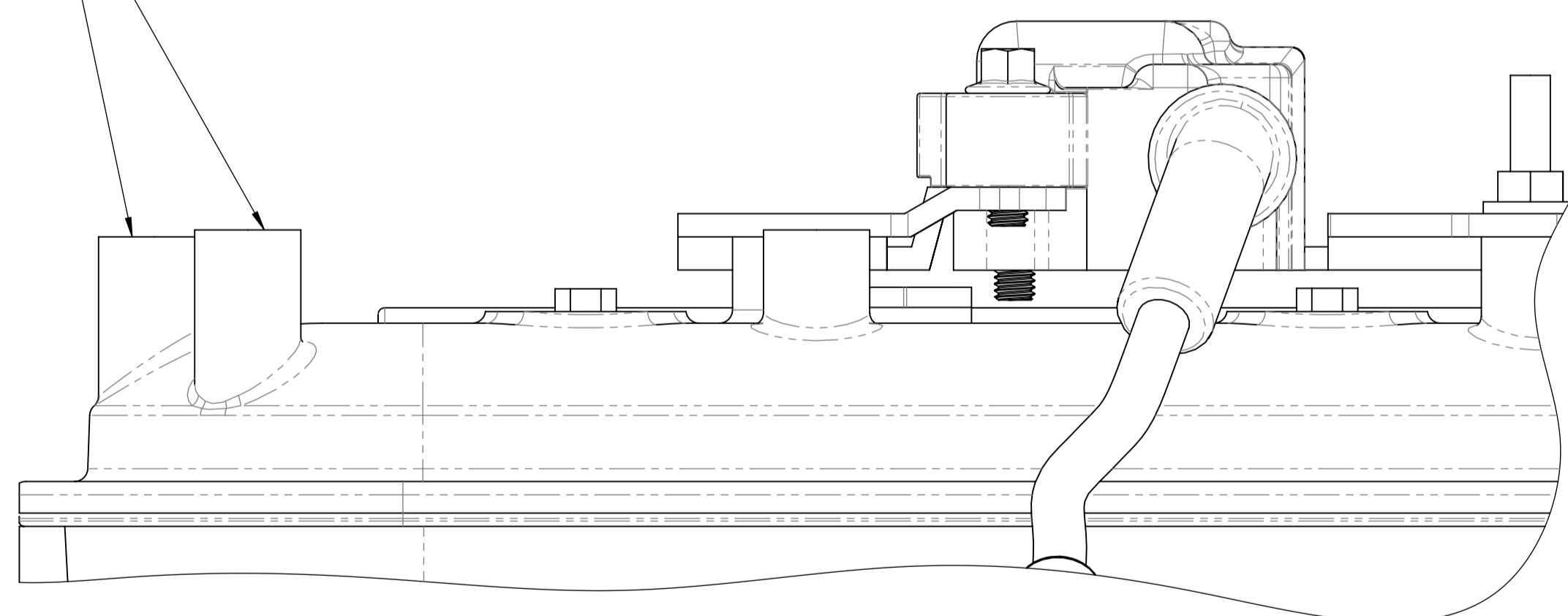

SIDE VIEW (1)



DRAWN	GDK 15/07/2021	TITLE	LS - Series Rocker Cover Coil Boss Modification	
DRAWING CHECKED	PAM 12/08/2021	SCALE: 1:2:1	DRAWING/PART NUMBER	REV No.
FINISHED WEIGHT: kg		DRAWING 1 of 1	LS - ACCMOD - 02	0

LS - SERIES PASSENGER SIDE COIL BRACKET MODIFICATION FOR COIL RELOCATION BRACKET MFC20020 (ROCKER COVERS IN FACTORY POSITION)

REMOVE THE HATCHED AREA
AS SHOWN TO ALLOW
FITMENT OF THE COIL
RELOCATION BRACKET

STANDARD PASSENGER SIDE
COIL BRACKET

MODIFIED PASSENGER SIDE
COIL BRACKET

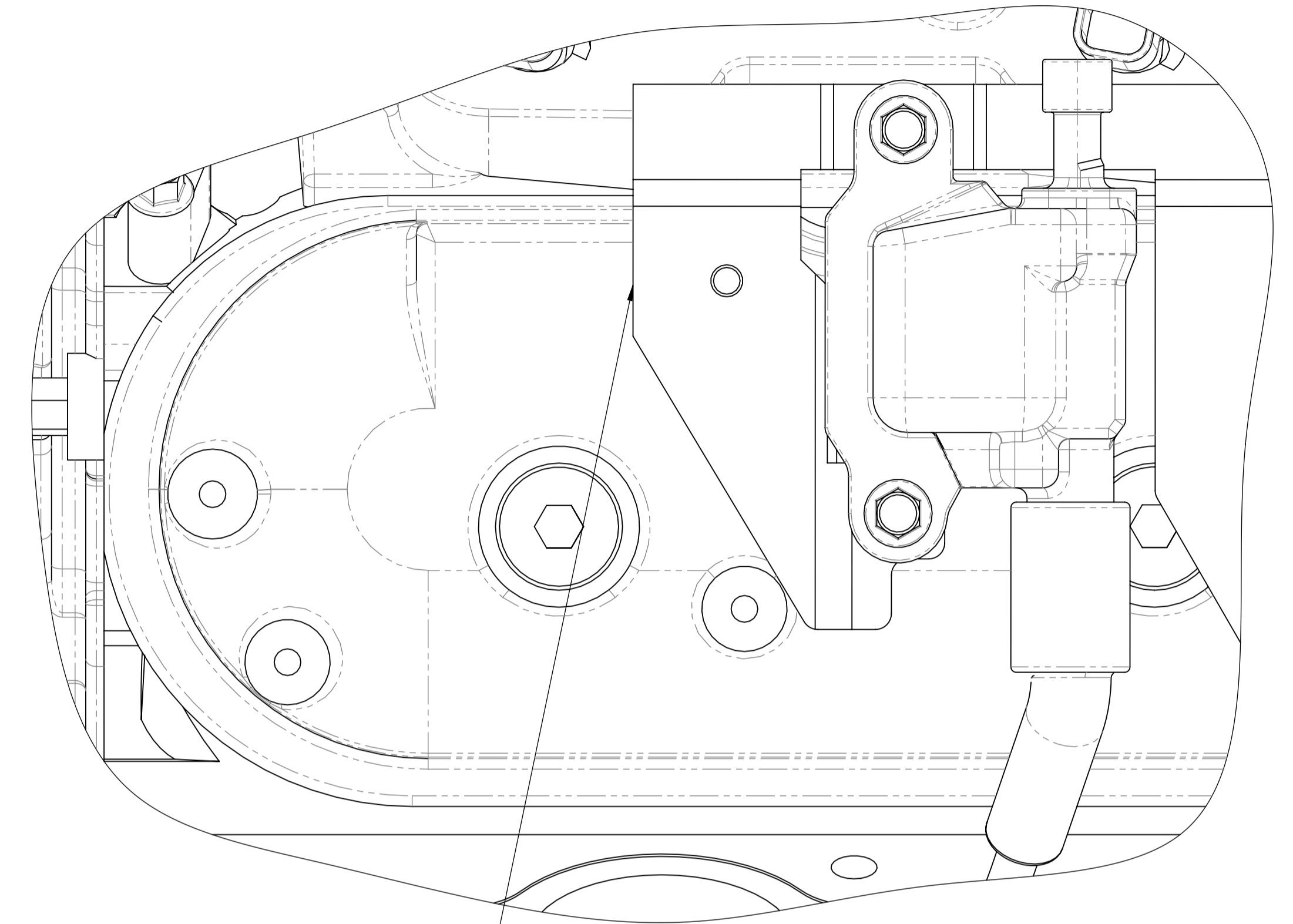
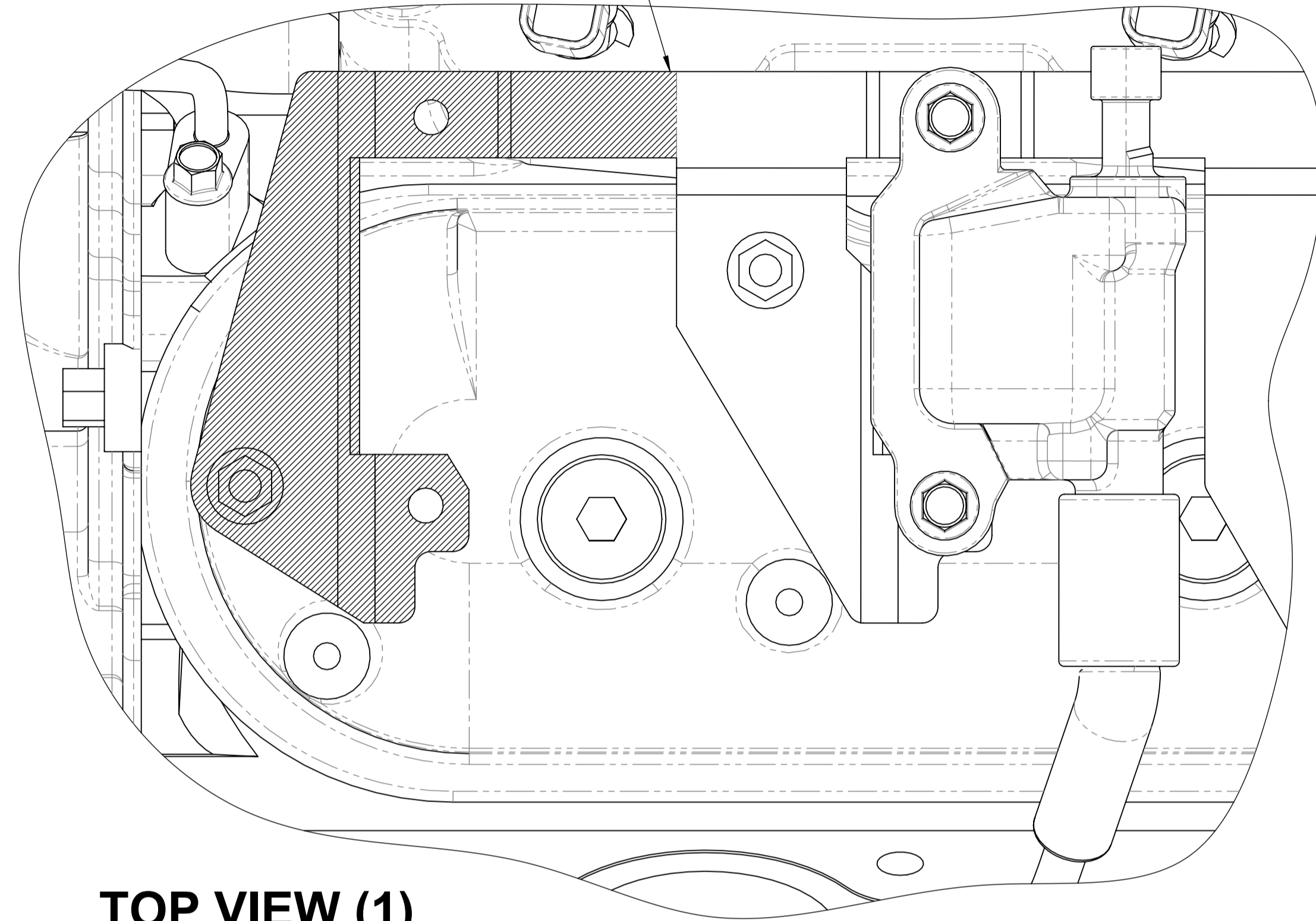

TOP VIEW (1)

TOP VIEW (2)

REUSE FACTORY BOLTS

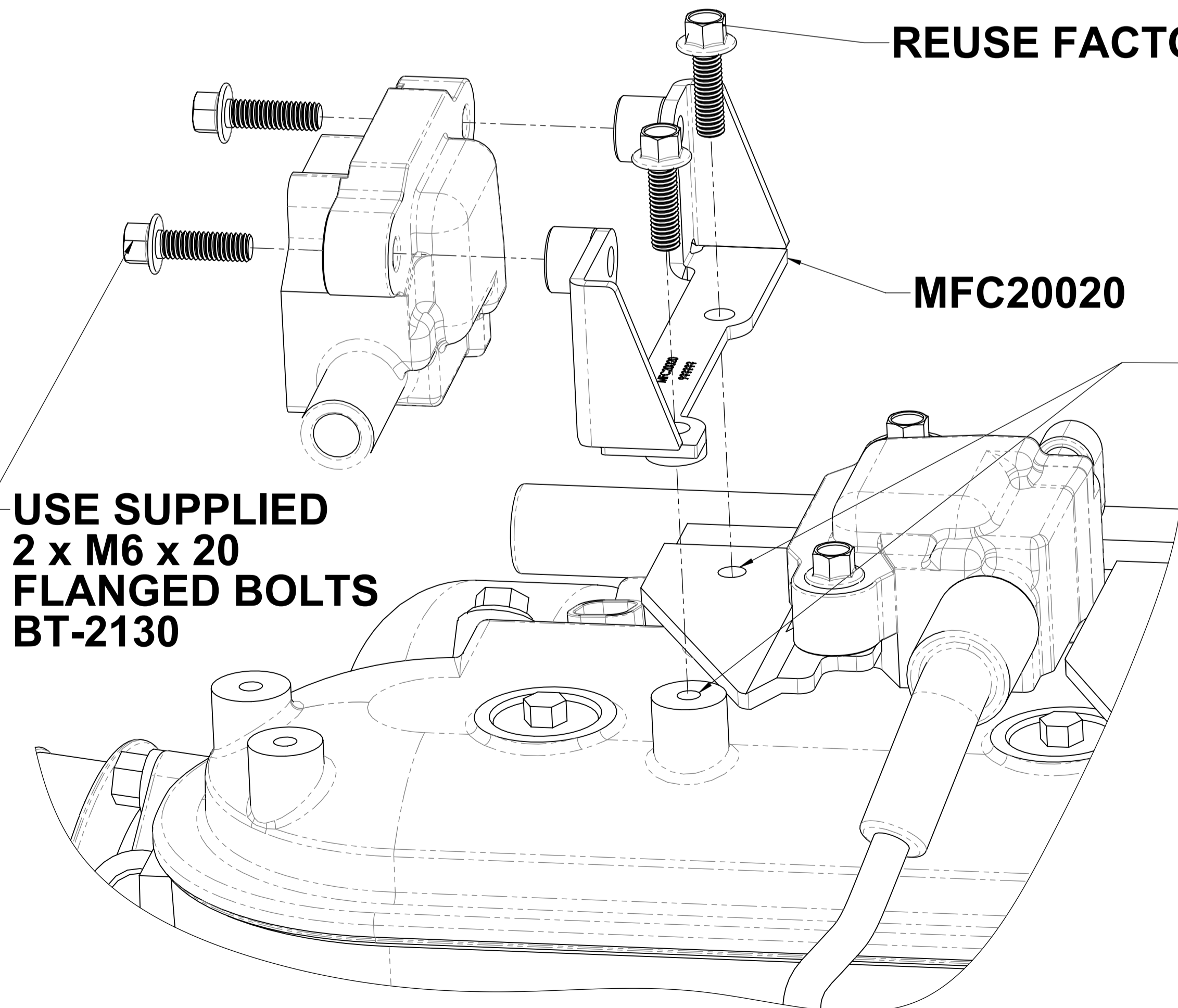

USE SUPPLIED
2 x M6 x 20
FLANGED BOLTS
BT-2130

MFC20020

REASSEMBLE THE LS COIL TO
MFC20020 IN THE ORIENTATION
SHOWN THEN FASTEN MFC20020
TO THE MODIFIED COIL BRACKET
& MOUNTING BOSS ON THE ROCKER
COVER AS SHOWN IN THE
EXPLODED VIEW

ROCKER COVER
MODIFICATION
IS REQUIRED BEFORE
COIL RELOCATION

REFER TO DRAWING:-

(LS - ACCMOD - 01)
LS - SERIES ROCKER COVER
LIP MODIFICATION

(LS - ACCMOD - 02)
LS - SERIES ROCKER COVER
COIL BOSS MODIFICATION

MODIFIED PASSENGER SIDE
COIL BRACKET AS SHOWN IN
TOP VIEW (2) & SIDE VIEW (2)

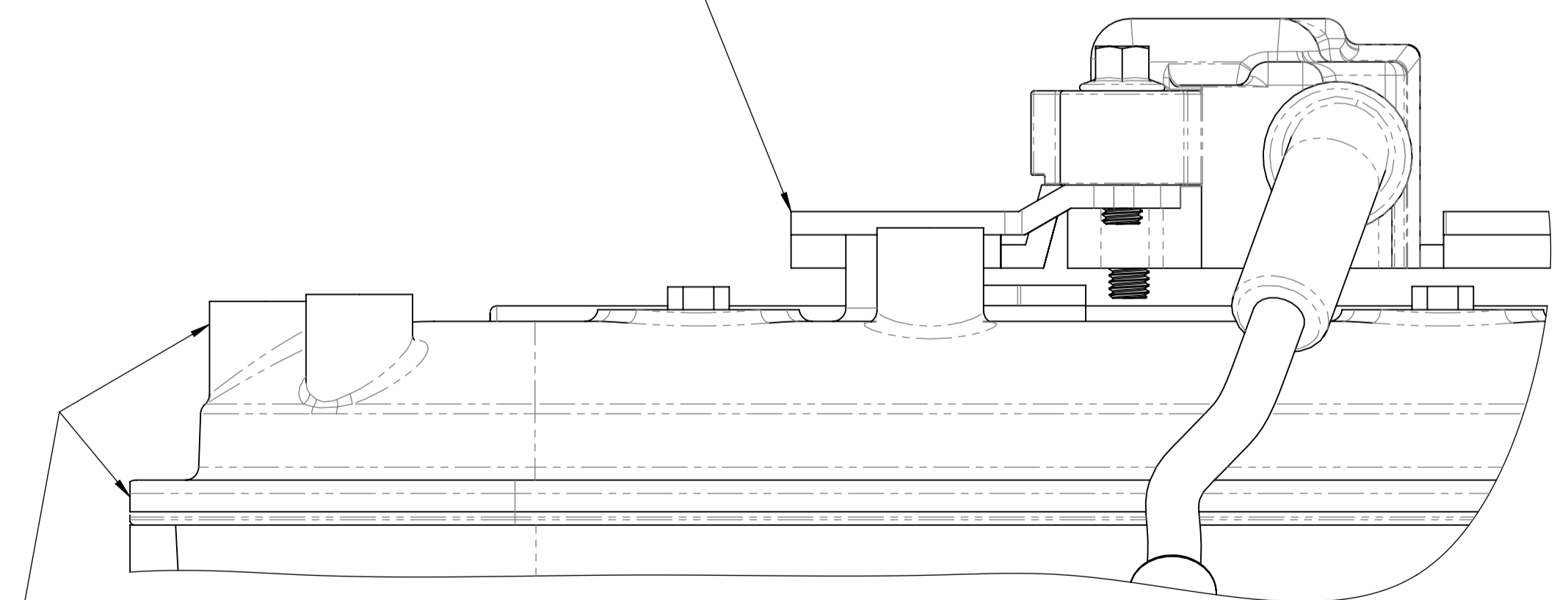

SIDE VIEW (2)

EXPLODE VIEW

DRAWN	GDK 15/07/2021	TITLE	LS - Series Passenger Side Coil Bracket Modification	
DRAWING CHECKED	PAM 12/08/2021	SCALE: 1:2:1	DRAWING/PART NUMBER	REV No.
FINISHED WEIGHT: kg		DRAWING 1 of 1	LS - ACCMOD - 04	0

LS1 TENSIONER GRIND TEMPLATE

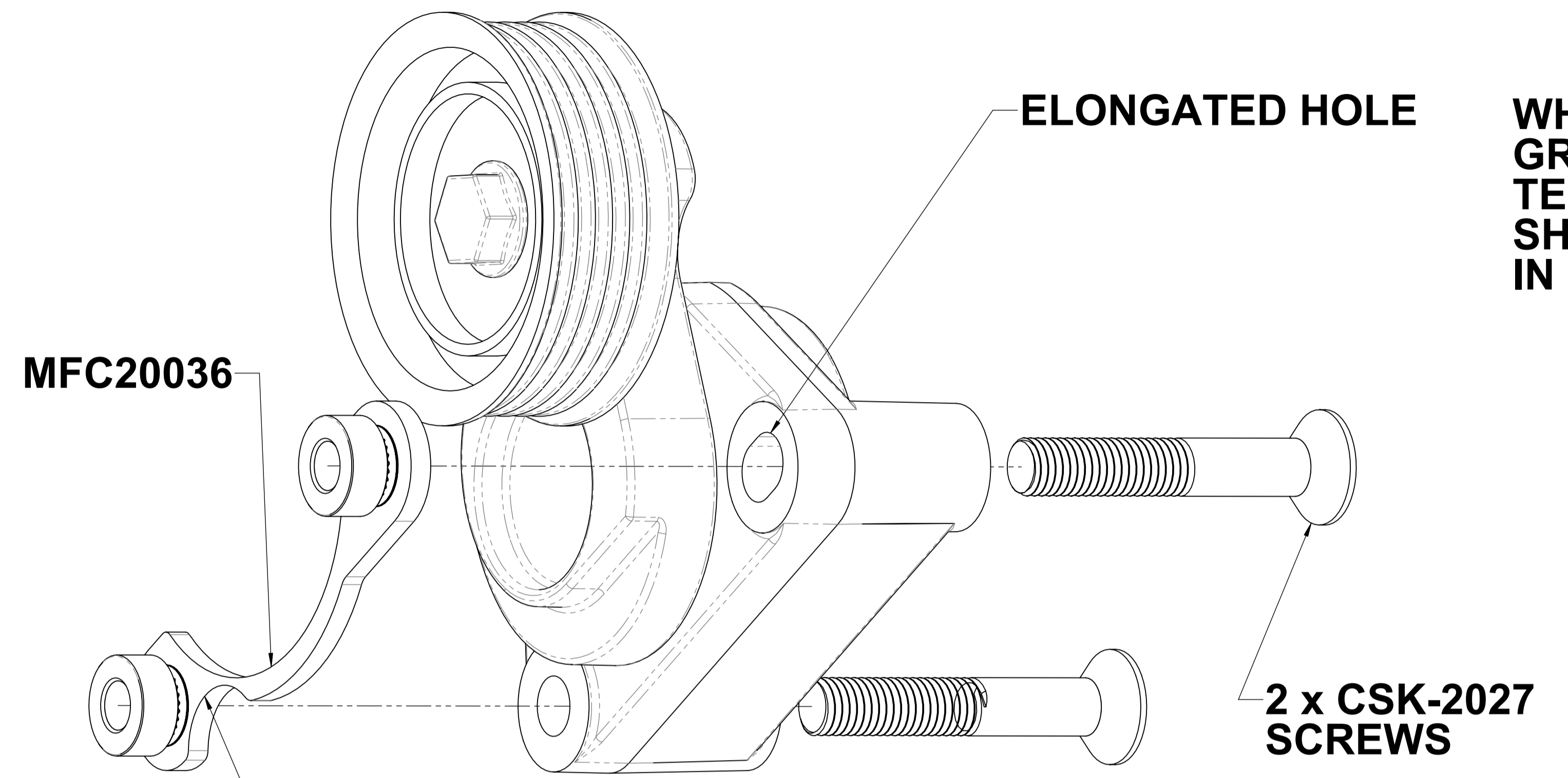

WHEN ASSEMBLING THE GRIND TEMPLATE TO THE TENSIONER, THE TEMPLATE SHOULD SIT AS SHOWN IN FRONT VIEW (1)

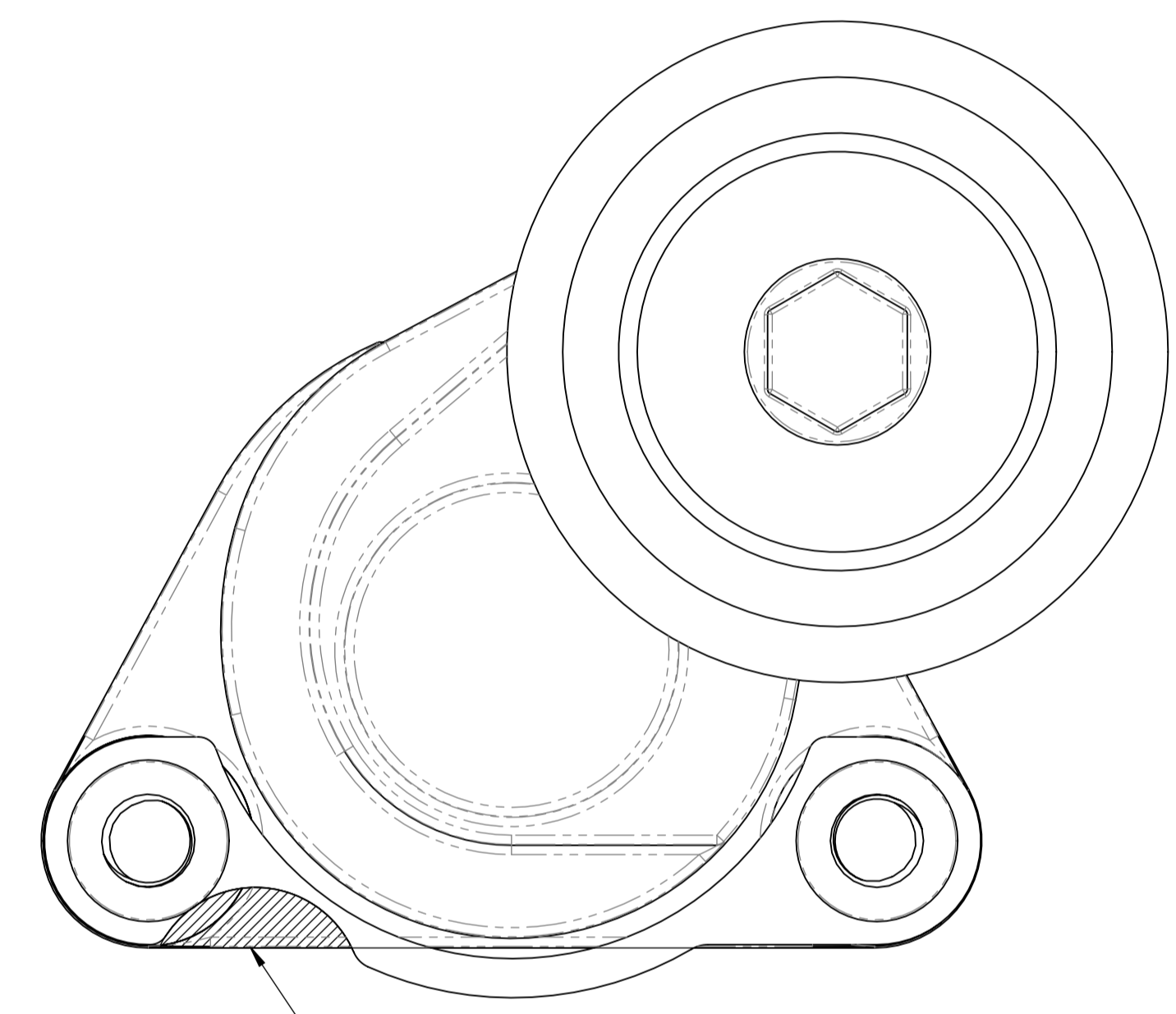

FRONT VIEW (1)

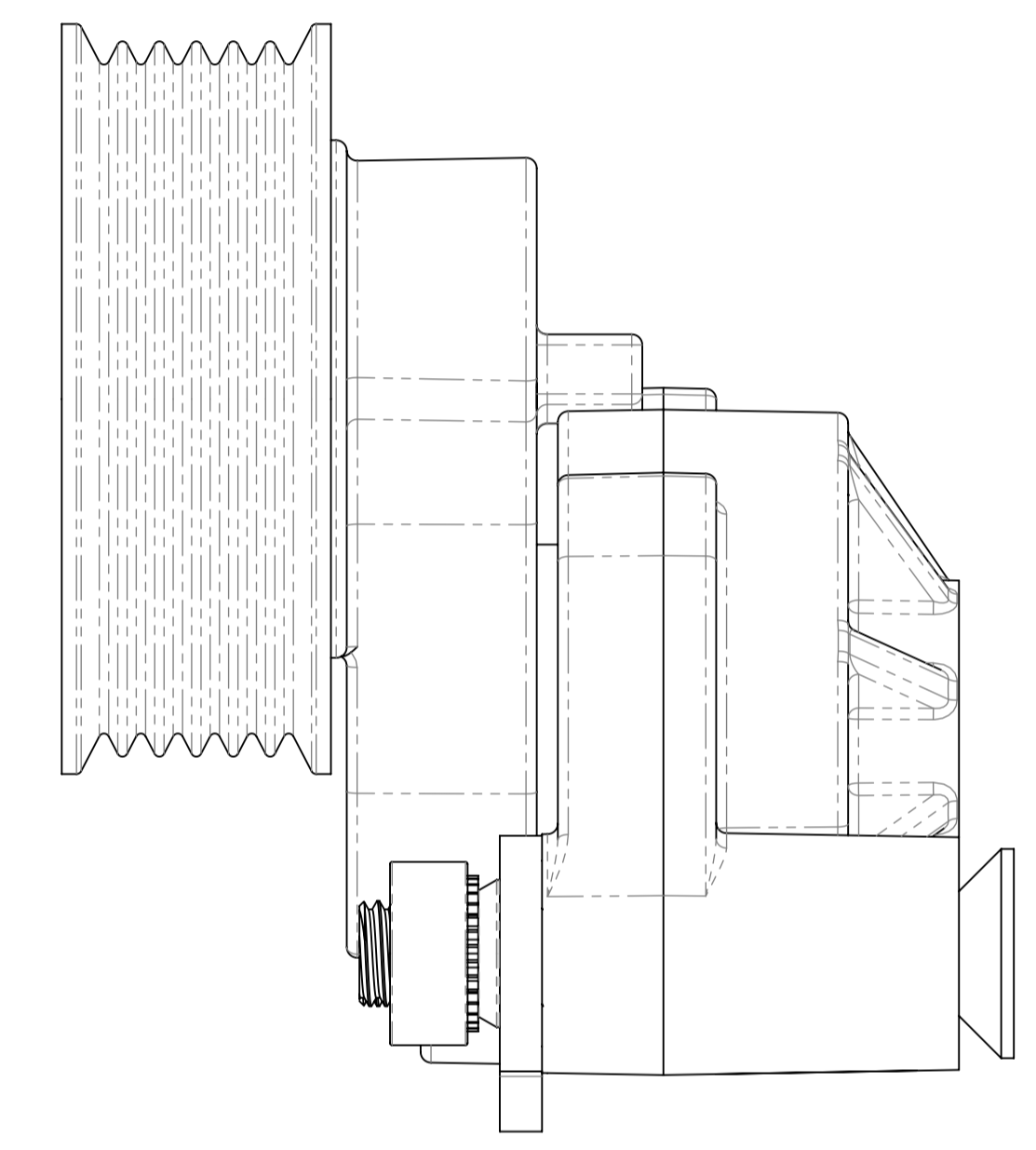

SIDE VIEW (1)

WHEN THE HATCHED AREA HAS BEEN GROUND OUT THE CLEARANCE SHOULD APPEAR AS SHOWN

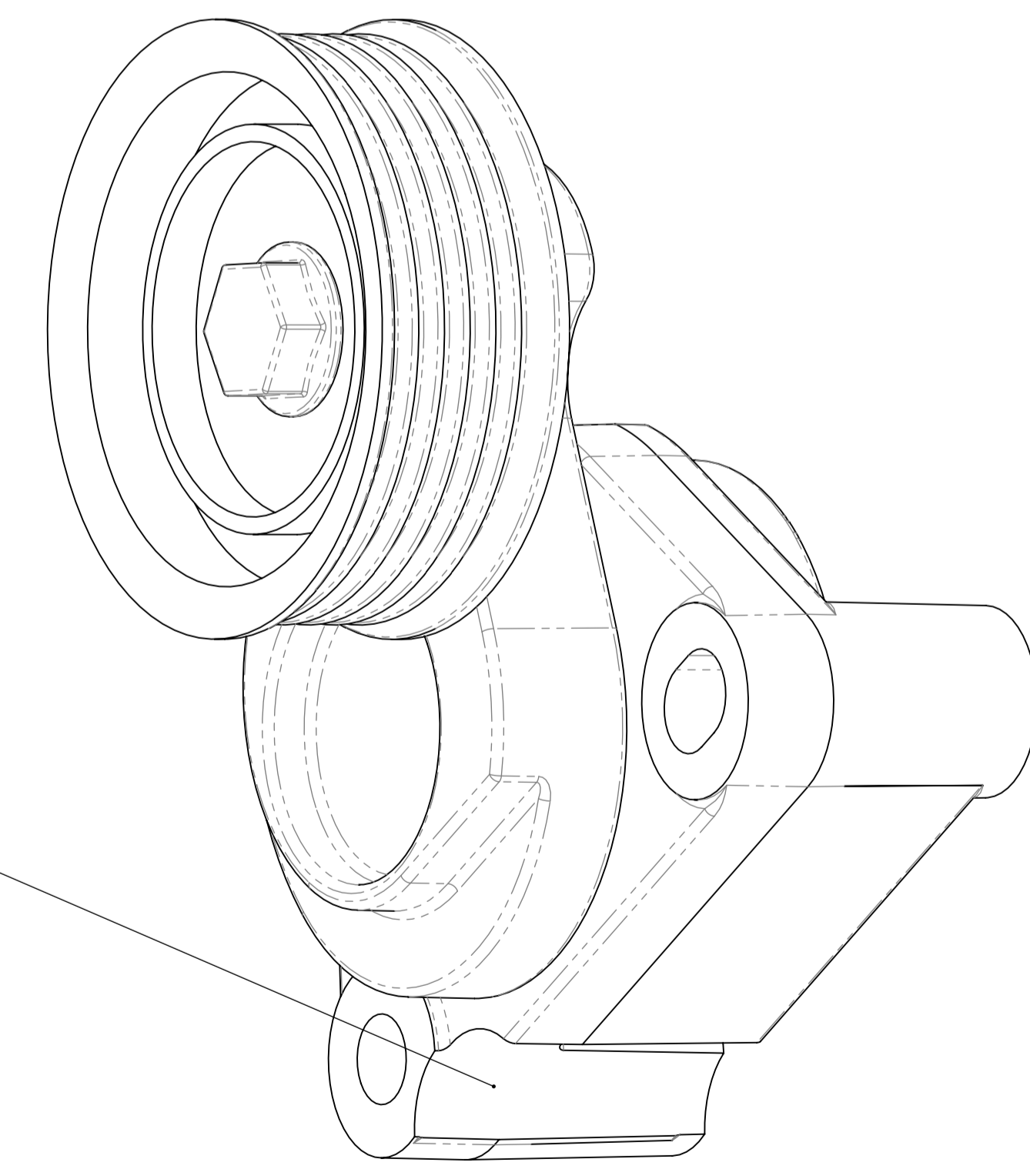

DRAWN	GDK 15/07/2021	TITLE:	LS1 Tensioner Grind Template	
DRAWING CHECKED	PAM 12/08/2021	SCALE: 1.5:1	DRAWING/PART NUMBER	REV No.
FINISHED WEIGHT: kg		DRAWING 1 of 1	LS - ACCMOD - 10	0

LS1/2/3 WATER PUMP GRIND TEMPLATE

WHEN ASSEMBLING THE GRIND TEMPLATE TO THE WATER PUMP, THE TEMPLATE SHOULD SIT AS SHOWN IN FRONT VIEW (1)

HALF CIRCLE CUT OUT

MFC20037

2 x CSK-2010 SCREWS

REMOVE THE HATCHED AREA AS SHOWN

WHEN THE HATCHED AREA HAS BEEN GROUND OUT THE CLEARANCE SHOULD APPEAR AS SHOWN

FRONT VIEW (1)



DRAWN	GDK 15/07/2021	TITLE:	LS1/2/3 Water Pump Grind Template	
DRAWING CHECKED	PAM 12/08/2021	SCALE: 1:1	DRAWING/PART NUMBER	REV No.
FINISHED WEIGHT: kg		DRAWING 1 of 1	LS - ACCMOD - 11	0

LS WATER PUMP TENSIONER MOUNT OFFSETS

THE LS1 OR VZ LS2 WATER PUMP TENSIONER MOUNTS WILL HAVE A 2mm GREATER OFFSET IN RELATION TO THE LS2/3 WATER PUMP TENSIONERS MOUNTS AS SHOWN

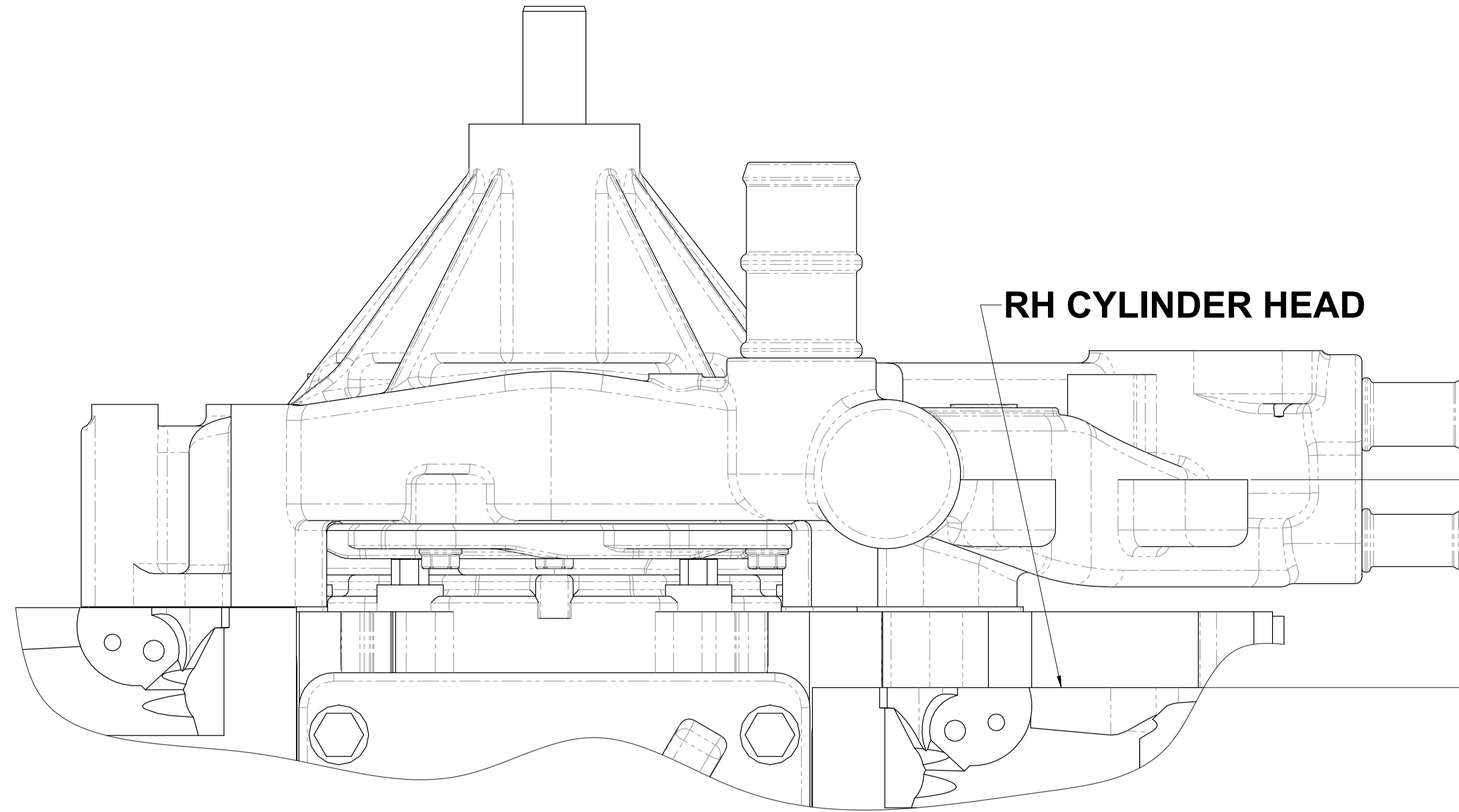

LS1 TENSIONER MOUNT OFFSET (mm)

LS1 OR VZ LS2 WATER PUMP

PRIOR TO FITTING THE ACCESSORY KIT CONFIRM THE OFFSET OF THE TENSIONER MOUNTS BY MEASURING THE OFFSET FROM THE RH CYLINDER HEAD THE OFFSET INCLUDES THE 1.5mm WATER PUMP GASKET

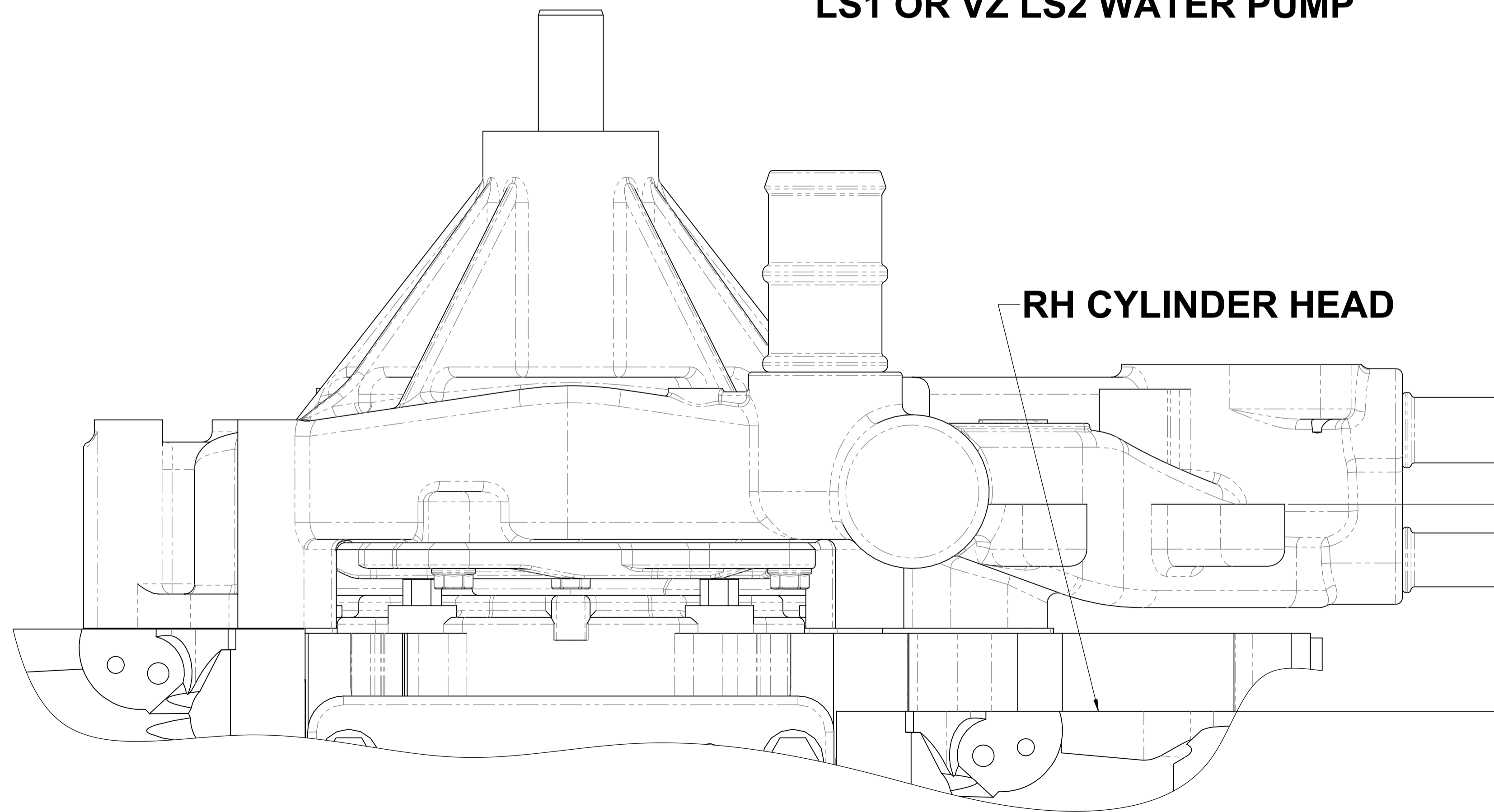

LS2/3 TENSIONER MOUNT OFFSET (mm)

LS2/3 WATER PUMP



DRAWN	GDK 15/07/2021	TITLE	LS Water Pump Tensioner Mount Offsets	
DRAWING CHECKED	PAM 12/08/2021	SCALE: 1:1	DRAWING/PART NUMBER	REV No.
FINISHED WEIGHT: kg		DRAWING 1 of 1	LS - INFO - 02	0

MARKS 4WD LS WATER PUMP

1:- THE GRIND CLEARANCE FOR THE LS1/ VZ LS2 TENSIONER & TENSIONER OFFSET MUST BE DONE PRIOR TO ASSEMBLING THE KIT

2:- ONCE THE GRIND CLEARANCE IS DONE MOUNT THE RH BASE PLATE OF THE KIT TO THE RH CYLINDER HEAD WITH THE SUPPLIED BOLTS

3:- MOUNT THE TENSIONER & MFC21085 SPACER (ORIENT AS SHOWN) TO THE MOUNTING FACE OF THE WATER PUMP USING AN OEM BOLT (M10x1.5x65) BEFORE ASSEMBLING THE KIT

FOLLOW STEPS 1,2,3,4,5 IN THAT ORDER

4:- THE ELONGATED SLOT OF THE TENSIONER WILL SIT DIRECTLY ONTO THE RH BASE PLATE SPACER OF THE KIT **(NO SHIM REQUIRED)**

5:- FW-2010 IS HELD CAPTIVE TO THE MOUNTING FACE OF THE WATER PUMP BY THE RH FRONT PLATE SPACER OF THE KIT WHEN ASSEMBLED

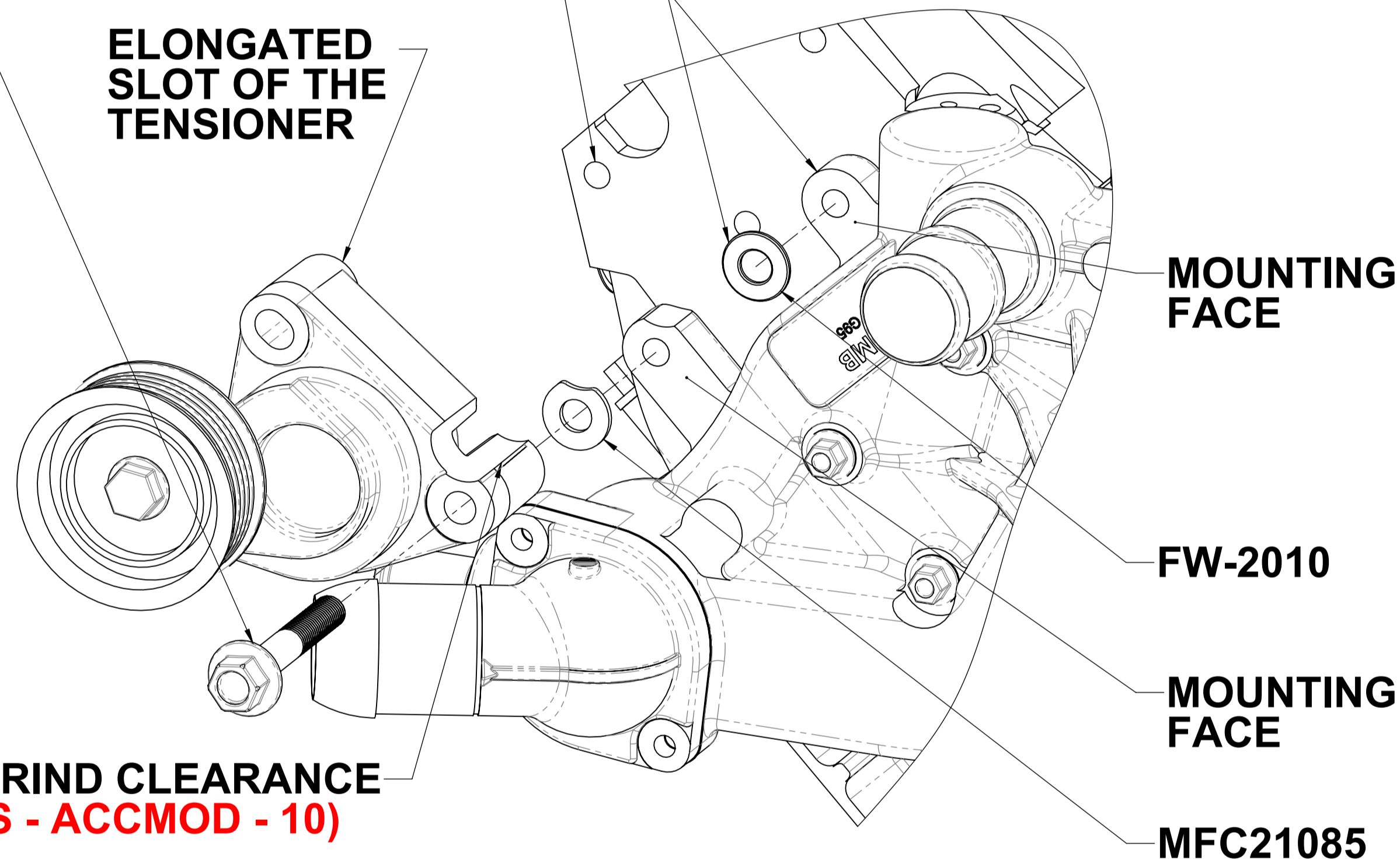

1:- TENSIONER OFFSET IS IN (mm) **62.7 (LS - INFO - 02)**

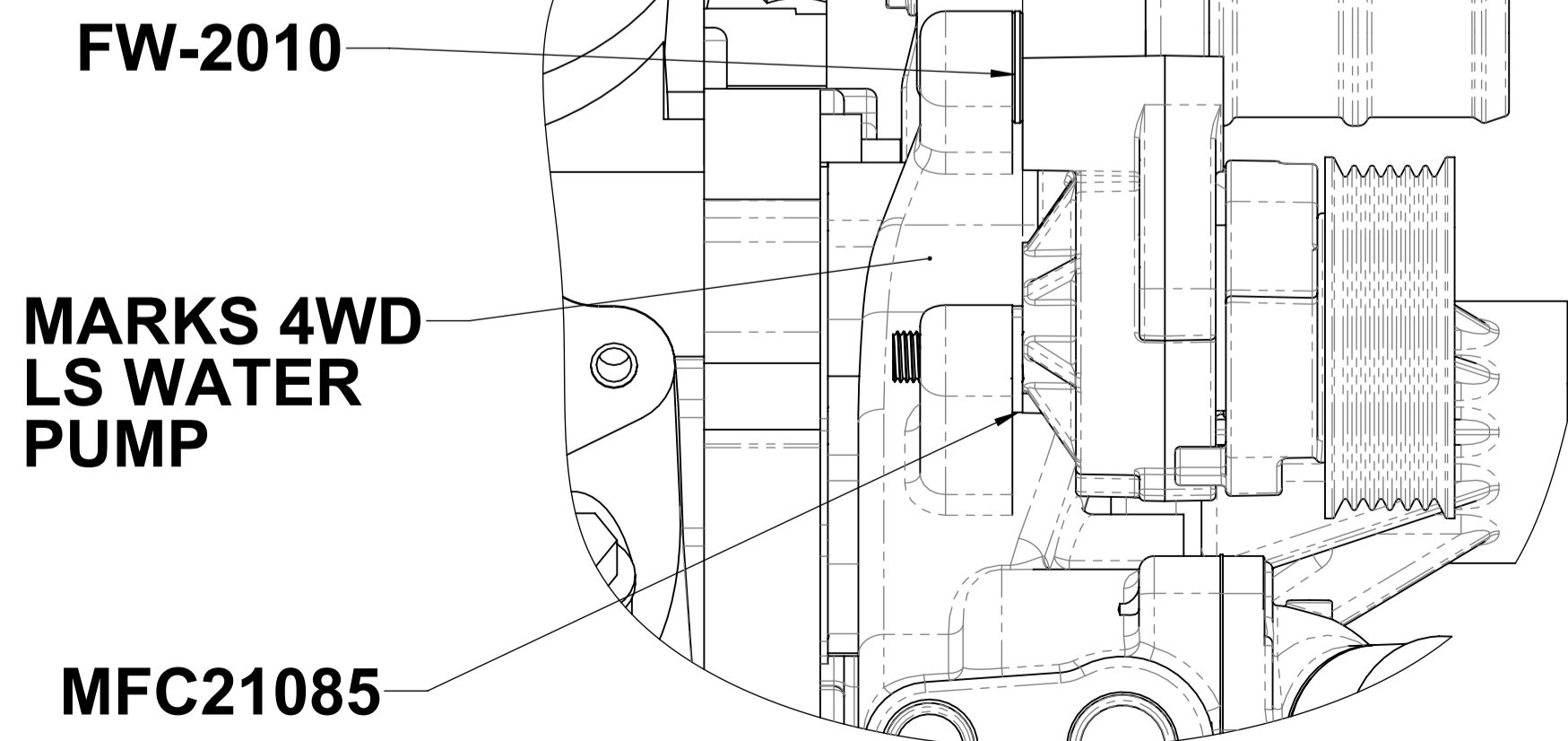

SIDE VIEW (1)

LS1/ VZ LS2 TENSIONER ASSEMBLY FOR RH KIT

1:- THE GRIND CLEARANCE FOR THE WATER PUMP & LS1/ VZ LS2 TENSIONER & TENSIONER MOUNT OFFSET MUST BE DONE PRIOR TO ASSEMBLING THE KIT

2:- ONCE THE GRIND CLEARANCE IS DONE MOUNT THE RH BASE PLATE OF THE KIT TO THE RH CYLINDER HEAD WITH THE SUPPLIED BOLTS

3:- MOUNT THE TENSIONER (ORIENT AS SHOWN) DIRECTLY TO THE MOUNTING FACE OF THE WATER PUMP USING AN OEM BOLT (M10x1.5x65) BEFORE ASSEMBLING THE KIT

FOLLOW STEPS 1,2,3,4,5 IN THAT ORDER

4:- THE ELONGATED SLOT OF THE TENSIONER WILL SIT DIRECTLY ONTO THE RH BASE PLATE SPACER OF THE KIT **(NO SHIM REQUIRED)**

5:- THE RH FRONT PLATE SPACER OF THE KIT WILL SIT DIRECTLY ONTO THE MOUNTING FACE OF THE WATER PUMP WHEN ASSEMBLED

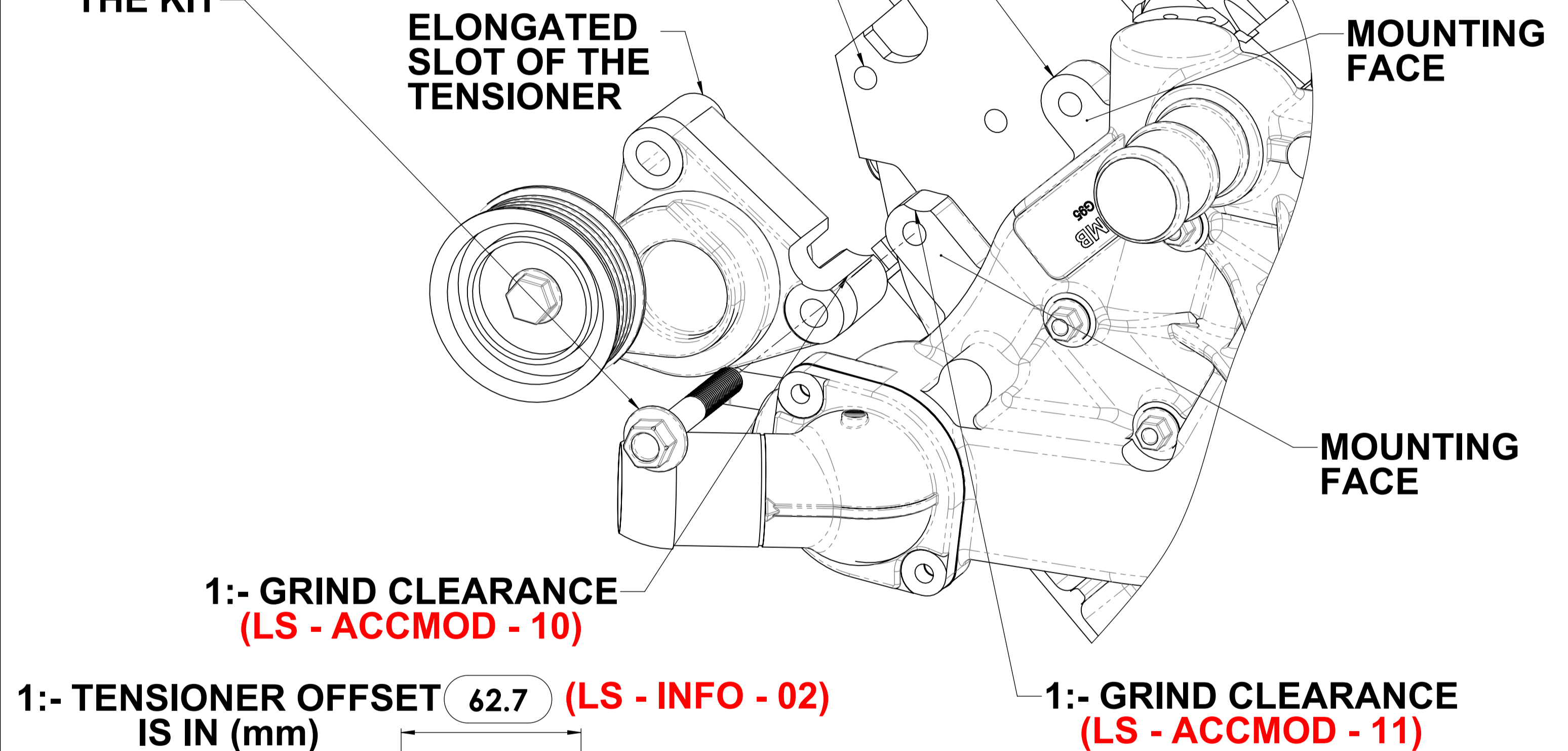

1:- TENSIONER OFFSET IS IN (mm) **62.7 (LS - INFO - 02)**

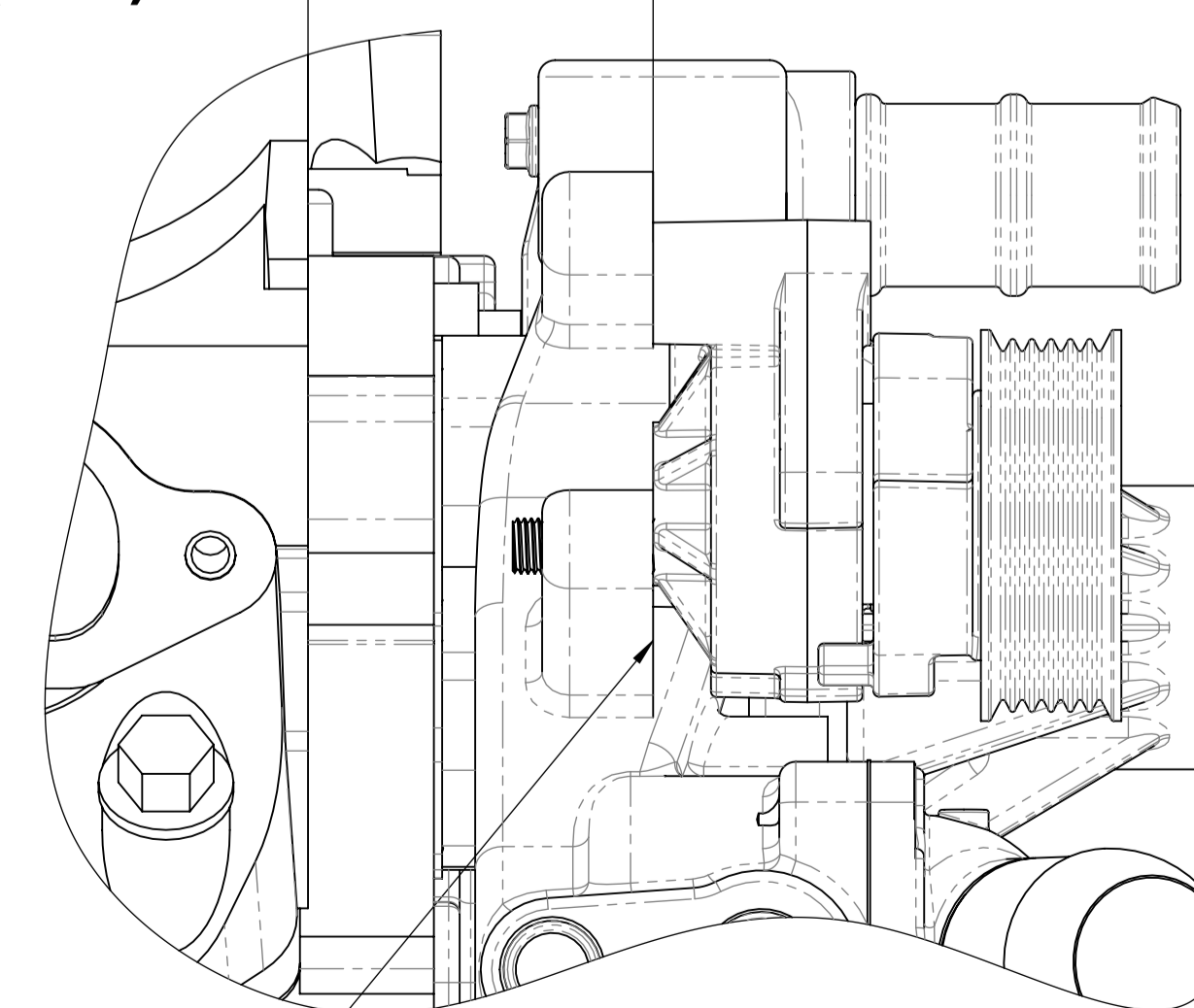

LS1/ VZ LS2 WATER PUMP SIDE VIEW (2)

VERIFY THE CORRECT OEM OFFSET FOR THE LS1 WATER PUMP IS @ 62.7mm AS SHOWN IN SIDE VIEW (2)

THE SUPPLIED SPACERS MFC21085 & FW2010 ARE 2mm THICK & SIT DIRECTLY ON THE MOUNTING FACES OF THE MARKS 4WD LS WATER PUMP AND FIX THE CORRECT OFFSET @ 62.7mm AS SHOWN IN SIDE VIEW (1)



DRAWN	GDK 15/07/2021	TITLE	LS1/VZ LS2 Tensioner Assembly For RH Kit
DRAWING CHECKED	PAM 12/08/2021	SCALE: 0.75:1	DRAWING/PART NUMBER
FINISHED WEIGHT: kg		DRAWING 1 of 1	REV No. LS - INFO - 06 0