

REFER TO MFK40375

ITEM NO.	PART NUMBER	DESCRIPTION	QTY.
1	LS Series Engine	OEM Pulley Positions (LS1/LS2/LS3)	1
2	MFC640G3	Adaptor Water Temp Gen3 V8 to GQ	1
3	MFC971	Adaptor Spigot Bearing GM to L/C	1
4	MFC1908	Input Shaft - 26T GM V8 to Patrol GQ/GU	1
5	MFC1913	Clutch Hose - Master Cylinder to Internal Slave	1
6	MFG1913	Clutch Master Cylinder - 1905 Kit	1
7	MFC1917	Banjo Bolt - 3/8" x 22	1
8	MFG40340	Clutch Actuator Assembly	1
9	MFC40341	Cover Plate Flywheel LS	1
10	MFC40375	LS V8 Oil Pressure Sensor Banjo Bolt - M16 x 1.5	1
11	MFC40380	M16 Banjo Shell x 1/8" BSPT	1
12	6202-2RS-C3	Ball Bearing 15 x 35 x 11 Skf	1
13	32113VB000	Seal 32 x 45 x 7	1
14	BQ8095	Banjo Bolt - 10 x 1mm	1
15	BT-2110	BOLT - M10 x 1.5 x 40	9
16	BT-2360	Bolt - M12 x 1.75 x 35mm - H/T	6
17	FW-2020	Flat Washer - M12 x 24 x 1.5 - S/S	6
18	BQ1016	Washer - Copper M10	2
19	BQ3858	Washer - Copper - 3/8"	2
20	CWC46	Washer - Copper - M12 x 16mm	1
21	CWC51	Washer - Copper - M16 x 22 x 1.5mm	3
22	O2N64IH-04	1/4" NPT Internal Hex Plug	1

THREAD LOCK COMPOUND
M10 BOLTS (ITEM 15)
M12 BOLTS (ITEM 16)
(USE MEDIUM STRENGTH
THREAD LOCK)

TORQUE SPECIFICATIONS
M10 BOLTS (ITEM 15) - 45Nm
M12 BOLTS (ITEM 16) - 75Nm

B FLUSH POSITION

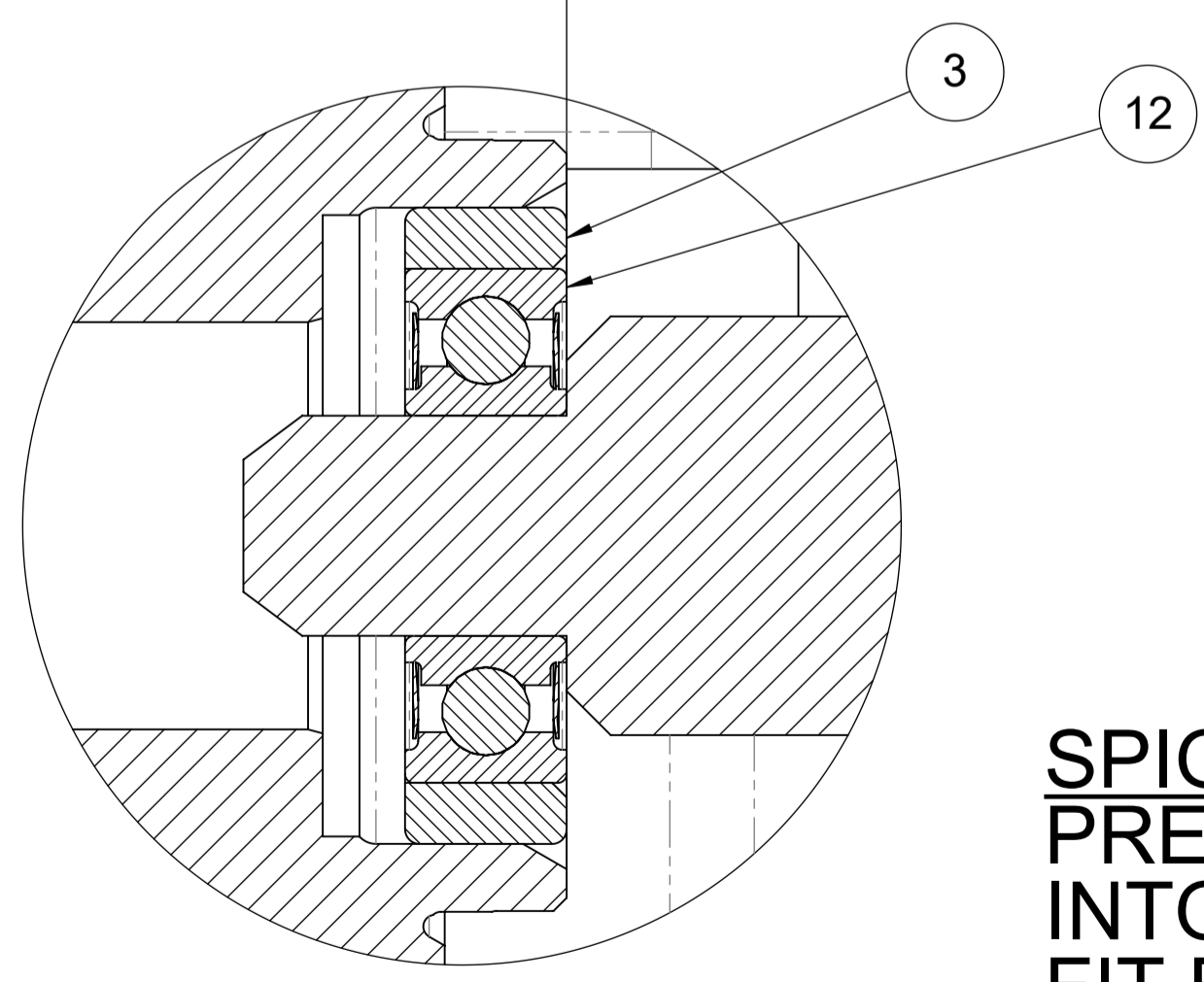

SPIGOT & BEARING INSTALLATION
PRESS ITEM 12 (BEARING)
INTO ITEM 3 (ADAPTOR SPIGOT)
FIT FLUSH INTO CRANK
AS SHOWN IN VIEW - A



DRAWN	GDK 16/09/2021	TITLE:	Bell Housing Adaptor Kit
DRAWING CHECKED	PAM 16/09/2021	SCALE: 1:2.5	- LS V8 to Patrol
FINISHED WEIGHT: 269.27 kg		DRAWING/PART NUMBER	MFK1905
		REV No.	0