

# SCAVENGER SNORKELS

## TOYOTA LANDCRUISER

### VDJ FACELIFT

# INSTALLATION MANUAL





SCAVENGER is a registered trademark of Work Air Technologies Pty Ltd.

- Prior to commencing the installation of the SCAVENGER Snorkel for your Toyota LandCruiser VDJ V8 Facelift, please read this installation manual carefully and follow step by step. Ensure that you have the correct kit for your LandCruiser by confirming your airbox is the same as shown in the images of this installation manual.
- It is recommended that only experienced and competent personnel may install the SCAVENGER Snorkel Advanced Air Intake System.
- Ensure you have all components listed in the parts list below prior to commencing this installation.
- Always place the SCAVENGER Snorkel on a soft work surface to prevent damage.
- Once holes are drilled in the vehicles body, ensure all edges are deburred and all swarf is removed, apply touch up paint/rust preventative coating on any newly exposed metal surfaces.
- Safety glasses to be worn when drilling.
- Estimated installation time 2.5 Hours.

(ITEM 13) SCAVENGER INSTALLATION KIT		
ITEM	DESCRIPTION	QTY
13-1	MOUNT, A-PILLAR	1
13-2	RADIATOR SHROUD DRILLING JIG	1
13-3	FITTING, BULKHEAD VACATOR (INCLUDES O-RING)	1
13-4	SPIGOT VACATOR HOSE	1
13-5	NUT, VACATOR HOSE CLAMP (INCLUDES O-RING)	1
13-6	HOSE CLAMP	2
13-7	FRONT MOUNT CNC ALUMINUM WASHER	1
13-8	FRONT MOUNT BOLT M8 X 70MM SS SOCKET HEAD	1
13-9	REAR MOUNT CNC ALUMINUM WAHSER	1
13-10	REAR MOUNT BOLT M8 X 40MM SS SOCKET HEAD	1
13-11	MIDDLE MOUNT BOLT M8 X 16MM HEX HEAD ZP INCL M8 X 20 MM ZP WAHSER	1
13-12	VACATOR MOUNT BOLT M6 X 20MM HEX HEAD ZP INCL M6 X 20MM ZP WASHER	3
13-13	A PILLAR MOUNT BOLT M8 X 16MM FLANGE HEX HEAD BLACK	4

SCAVENGER V8 FACELIFT BOM		
Item	Description	QTY.
1	SNORKEL, SCAVENGER LC70 V8 Facelift	1
2	ENCLOSURE SCAVENGER RHS	1
3	CYCLONIC ELEMENT, SCAVENGER	19
4	ELEMENT, FILTER	1
5	HOSE, VACATOR	1
6	VACATOR SHROUD	1
7	SPIGOT VACATOR HOSE	1
8	NUT, VACATOR HOSE CLAMP (INCLUDES O-RING)	1
9	AIRBOX ADAPTOR HOSE	1
10	FACEPLATE, SCAVENGER RHS	1
11	FACEPLATE MOUNT BOLTS, M6 X 16 BUTTON HEAD SS	9
12	RUBBER GROMMET, HOSE PASS THROUGH	1
13	SCAVENGER V8 FACELIFT INSTALLATION KIT	1

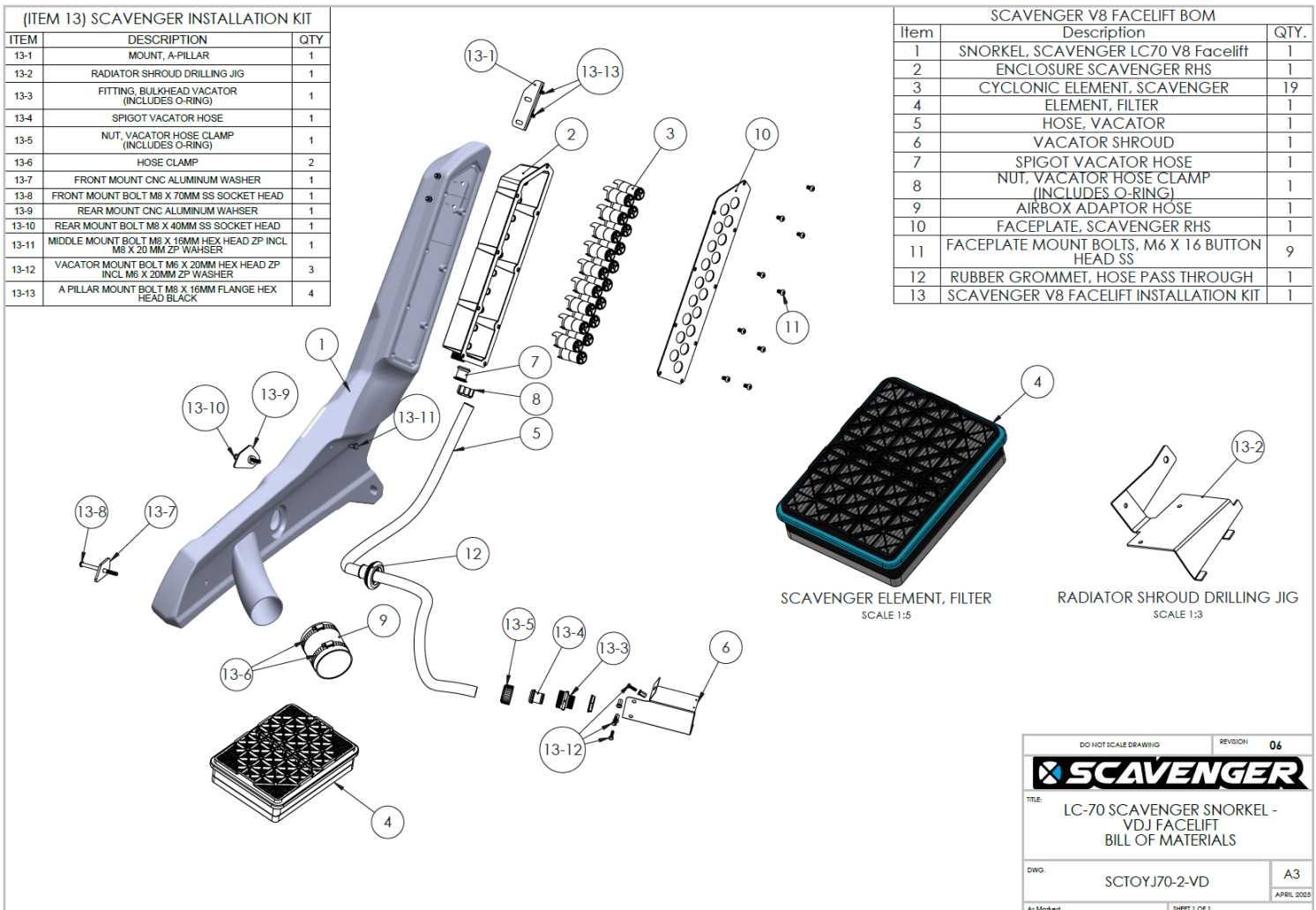

DO NOT SCALE DRAWING	REVISION	06
<b>SCAVENGER</b>		
TITLE: LC-70 SCAVENGER SNORKEL - VDJ FACELIFT BILL OF MATERIALS		
DWG:	SCTOYJ70-2-VD	A3
At Marked:		APRIL 2023
	SHEET 1 OF 1	

1. Remove the OEM Toyota LandCruiser snorkel and included parts in accordance with the manufacture service manual.



2. Release the four (4) metal clips securing the top of the air box in position.
3. Remove the Toyota OEM air filter and discard.



4. Release the two (2) hose clips securing the air intake hose to the top of the air box. Remove hose and set the top of the air box aside.



5. Cover the air intake to prevent ingress. (A clean cloth and masking tape is recommended).



6. Release the three (3) bolts securing the bottom of the air box to the chassis, and remove bottom of the air box.



7. Once the air box is removed, remove the two (2) bolts holding the Toyota OEM intermediate tube and flange in position. Remove and discard the intermediate tube and flange.



8. Place the two (2) drill templates on the front quarter panel of the vehicle, aligning up the template with the existing holes/cutouts in the quarter panel. Use masking tape to temporarily fix in position.
9. Centre punch the hole marked 50mm and 13mm as annotated on the paper template.



10. Drill 3mm pilot holes in the centre punch locations.
11. Using a 50mm hole saw, carefully drill the location marked 50mm on the drill template. Caution: Hole saws tend to grip the material and cause rotation of the drill. Only drill this hole if you are experienced and competent using a hole saw.
12. Using a 13mm drill bit, drill the 13mm hole as centre punched from the drill template.
13. Deburr, remove swarf and apply paint/rust preventative measures to the exposed metal surface.



14. Remove the three (3) bolts securing the radiator expansion tank in position. Note there is no need to drain the coolant from the expansion tank.



15. Using a cable tie, temporarily tie up the radiator expansion tank out of the way as shown in the image on the right. This will give you more space



to install the vacator shroud on the radiator fan shroud.

16. Place the radiator fan shroud drill jig provided in the kit on the radiator shroud as shown in the images. The folded edges on the drill jig fit into the shape of the shroud ensuring correct positioning of the holes.

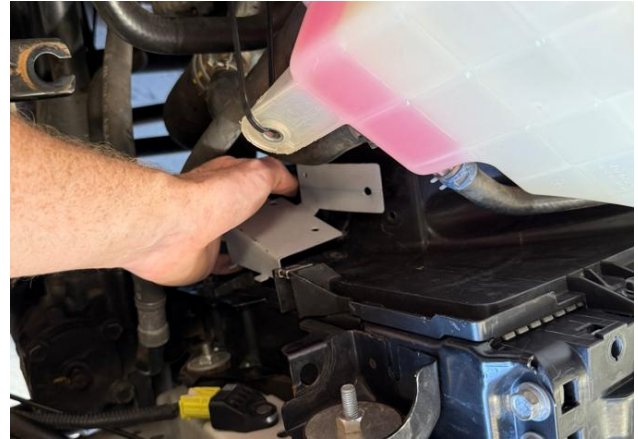

17. Using a 3mm drill bit, drill a pilot hole in the radiator shroud in all four (4) hole locations on the drill jig. **CAUTION! USE A PIECE OF METAL OR SIMILAR AT THE BACK OF THE FAN SHROUD TO PREVENT THE DRILL BIT FROM GOING IN TOO FAR AND DAMAGING THE RADIATOR. REMEMBER TO REMOVE THIS METAL PIECE ONCE ALL HOLES ARE DRILLED.** Tools such as a 90-degree drill or short drill bits will aid with this step.
18. Drill out the three (3) holes marked 6.5mm on the image with a 6.5mm drill bit.
19. Using a 35mm hole saw, drill out the hole marked 35mm in the image.
20. Fit the vacator shroud into the radiator fan shroud. Rotate the fan in a position that allows the vacator shroud to pass through. Align the holes up that have just been drilled with the vacuum shroud and tighten the three (3) M6 bolts.

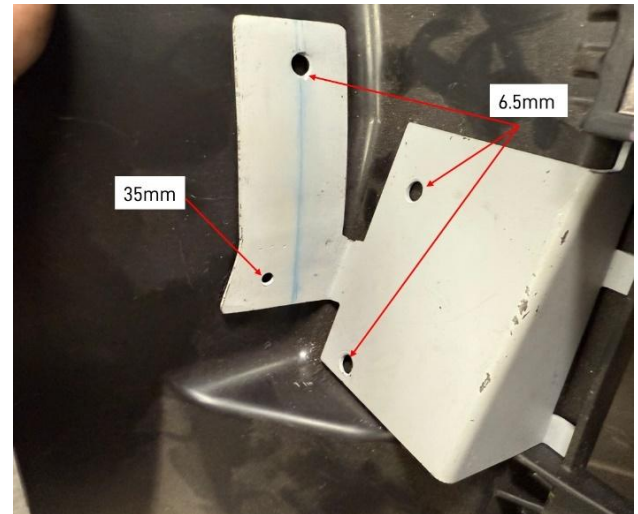

21. Remove the four (4) bolts holding the radiator shroud in place. Move the radiator shroud to allow additional space. Align the vacator shroud up and tighten the bolts. Once the Vacator shroud is fixed in position, re attach the radiator shroud using the four (4) bolts.

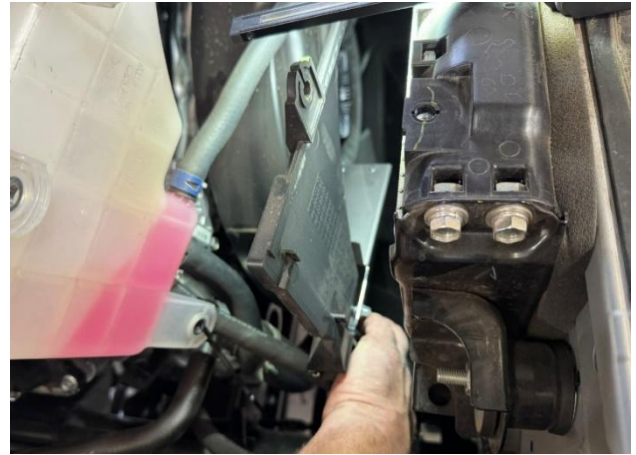

22. Check fitment of the vacator shroud to ensure adequate clearance from the fan and the radiator.

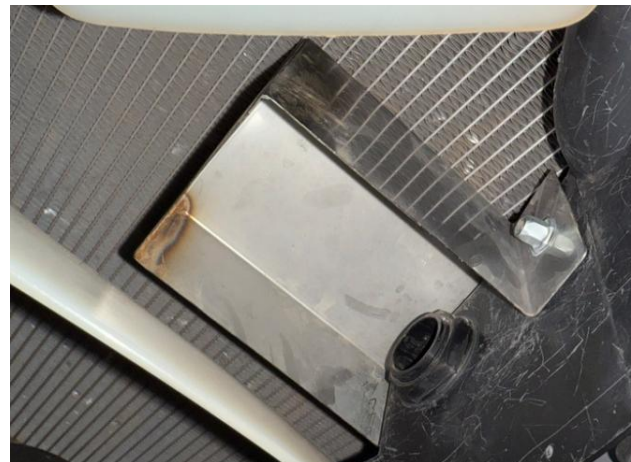

23. Once all the holes are drilled, fit the bulkhead Vacator fitting in place and tighten accordingly.



24. The SCAVENGER Snorkel is now ready to be installed.

25. Feed the vacator hose through the predrilled 50mm hole.

26. Fit the snorkel onto the vehicle, carefully manoeuvring the snorkel outlet through the cut out in the vehicles quarter panel. Be careful to find the correct angle for full insertion.



27. Using the bolts provided in the SCAVENGER installation kit, mount the snorkel to the quarter panel. Tighten bolts sufficiently.



28. Fix the snorkel body to the quarter panel by sufficiently tightening the M8 bolt and washer as seen in the image on the right.

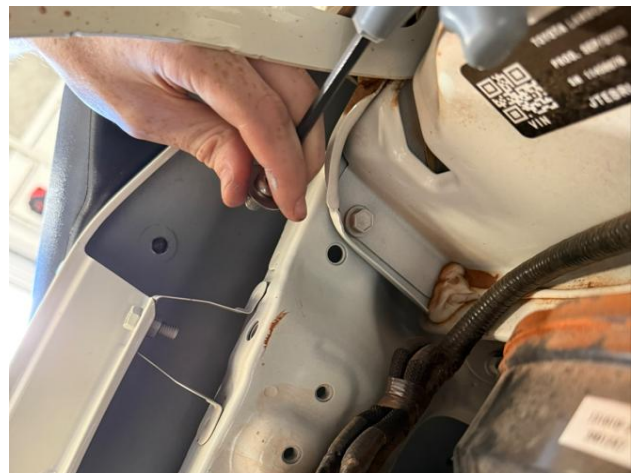

29. Fit the snorkel A-pillar bracket to the vehicle's A-pillar and tighten the four (4) bolts sufficiently to secure the snorkel to the A-pillar.



30. Attach the hose adaptor to the snorkel outlet at the air box location and secure in place via provided hose clamp. Tighten hose clamp hand tight at this stage. \*V8 Facelift hose adaptor included in the SCAVENGER kit may differ from the corresponding picture.



31. Attach the vacator hose to the bulkhead vacator fitting on the radiator fan shroud. Tighten the nut sufficiently by hand.



32. Once the vacator hose is fitted and nut is tight, cut the temporary cable tie holding the radiator expansion tank out of the way, and secure the expansion tank back in position via the three (3) bolts.



33. Route the vacator hose as shown in the image and secure with cables ties. Ensure there is a consistent fall in this pipe from the snorkel to the bulkhead vacator fitting to prevent pooling of water in the pipe. Cut the excess off the cable ties using flush cut pliers.

34. The air box can now be installed. Align the bottom of the air box and secure with the three (3) bolts, ensuring the silicone hose is correctly placed on the intake to the bottom of the air box. Use a small bit of WD40 on the airbox side of the silicone hose to assist with fitment.

35. Tighten the hose clamp sufficiently. \*V8 Facelift hose adaptor included in the SCAVENGER kit may differ from the corresponding picture.



36. Remove the cover used on the air intake to prevent accidental ingress and refit the top of the air box. Connect the air intake hose and tighten the hose clamps.

37. Install the top of the air box and attach air intake hose. Secure in position with hose clamp.



38. Install new SCAVENGER High Efficiency Air Filter and secure top of air box via the four (4) clips.

39. Take your time to double check that all bolts etc used to install the SCAVENGER Snorkel system are tight.



40. Your Toyota LandCruiser VDJ Facelift is now fully fitted with the SCAVENGER Snorkel Advanced Air Intake system. Time to get off road and enjoy knowing your vehicles engine is protected from dust.



SCAVENGER is a registered trademark of Work Air Technologies Pty Ltd.